

## ABL/AKL-Series Gear-Tooth Sensors

### Block Diagrams

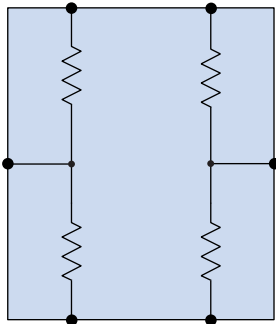

**ABL00x**

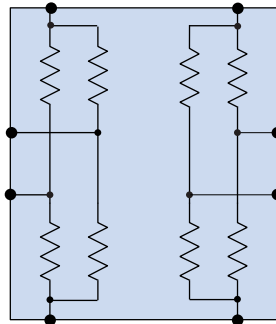

**ABL01x**

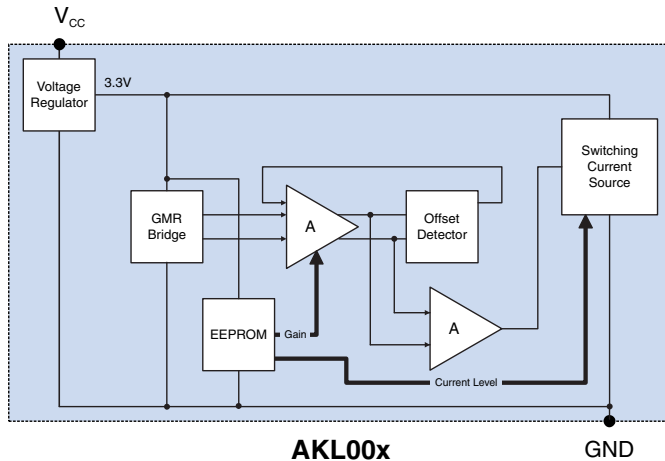

**AKL00x**

### Outputs

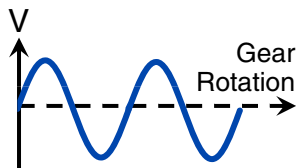

**ABL00x**  
Single-bridge analog sensor

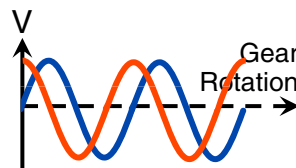

**ABL01x**  
Dual-bridge analog sensor

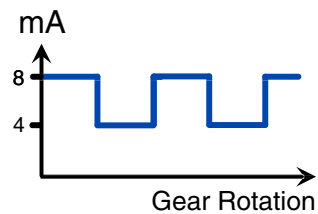

**AKL00x** digital gear-tooth sensor

### Features

- Wide airgap
- Analog and digital versions
- Large analog peak-to-peak signal
- Single- and dual-bridge versions
- Operating frequency to 1 MHz
- 150°C operating temperature
- Packages as small as 2.5 mm x 2.5 mm

### Applications

- Motion, speed, and position sensing
- Linear and rotational encoders
- Closed-loop servo systems
- Automotive sensors

### Description

ABL and AKL-Series Gear-Tooth Sensors are versatile, wide airgap sensors typically used with ferromagnetic gears and bias magnets.

Three standard spacings are available for use with gear pitches as small as 0.6 mm, to 6 mm or more.

ABL-Series analog sensors have differential sensor elements that provide sinusoidal outputs. Single- or dual-bridge configurations are available. Dual-bridge versions provide sine and cosine outputs for direction information.

AKL-Series sensors combine a sensor bridge with integrated signal processing to provide a 50% duty cycle digital output. Integrated signal processing includes gain and offset normalization. AKL-Series sensors are configured as two-wire devices, where the supply current indicates passing teeth.

## Absolute Maximum Ratings

ABL-Series Analog Gear-Tooth Sensors			
Parameter	Min.	Max.	Units
Supply voltage		30	Volts
Storage temperature	-65	170	°C
ESD (Human Body Model)		400	Volts
Applied magnetic field		Unlimited	Oe

AKL-Series Digital Gear-Tooth Sensors			
Parameter	Min.	Max.	Units
Supply voltage	-60	45	Volts
Continuous output current		16	mA
Junction temperature	-40	170	°C
Storage temperature	-65	170	°C
Junction temperature	-40	170	°C
ESD (Human Body Model)		2000	Volts
Applied magnetic field		Unlimited	Oe

## Operating Specifications

ABL-Series Analog Gear-Tooth Sensors						
Parameter	Symbol	Min.	Typ.	Max.	Units	Test Condition
Operating temperature	$T_{min}; T_{max}$	-50		150	°C	
Supply voltage	$V_{CC}$	0		30	V	
Resistance		4	5	7	kΩ	At 25°C
Offset voltage	$V_O$	-4		+4	mV/V	
Non-linearity				2	%	Unipolar field sweep across near operating range
Hysteresis				2	%	
Saturation of GMR sensor elements		-180		+180	Oe	
Single resistor sensitivity	$\Delta R/Oe$		0.04		%/Oe	
Maximum output			80		mV/V	
Resistance temperature coefficient	TCR		+0.11		%/°C	No applied field
Operating frequency	$f_{MAX}$	0	1		MHz	

AKL-Series Digital Gear-Tooth Sensors ( $T_{min}$ to $T_{max}$ ; $4.5\text{ V} < V_{CC} < 36\text{ V}$ unless otherwise stated)						
Parameter	Symbol	Min.	Typ.	Max.	Units	Test Condition
Operating temperature	$T_{min}; T_{max}$	-40		150	°C	
Supply voltage	$V_{CC}$	4.5		36	V	
Off-state supply current	$I_{OFF}$	3.4	4	4.8	mA	$V_{CC} = 12\text{V}$
On-state supply current	$I_{ON}$	7	8	9		
Output duty cycle		40	50	60	%	
Airgap					mm	
AKL001-12		1		3.5		
AKL002-12		1		2.5		
AKL003-12		1		2		
Operating frequency	$f_{MAX}$	DC		10	kHz	

## Operation

### *Biasing*

To detect gear teeth, a permanent magnet is required to generate a magnetic bias field. The sensor can then detect magnetic field variations as the gear tooth passes by.

Here are some tips for biasing:

- Because of GT Sensors' high sensitivity, small, inexpensive Ceramic 8 ferrite magnets can be used for most applications. Small sensors and magnets allow small circuit boards.
- Alnico 8 magnets can be used in high temperature applications.
- Rare-earth magnets are not recommended because they tend to saturate the sensors.
- Magnets and sensors can be placed on opposite sides of a 1.5 mm thick (0.062 inch) circuit board, which provides a convenient spacing for many applications (see Figure 1).
- The magnet can be glued to the circuit board using high-temperature epoxy adhesive.
- For more precise positioning, a pocket to hold the magnet can be machined into a thicker circuit board.
- If zero speed operation is not required, AC coupling the sensor removes the electrical offset induced by magnetic imperfections.
- If zero speed operation is required, zeroing the sensor output offset maximizes airgap (AKL-Series sensors have integrated zeroing).

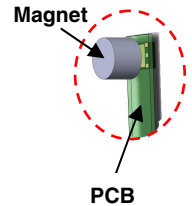

**Figure 1. Biasing magnet.**

### *Sensor orientation*

To align with the axis of sensitivity, sensors should be oriented with the gear teeth perpendicular to the length of the sensor as shown in Figure 2:

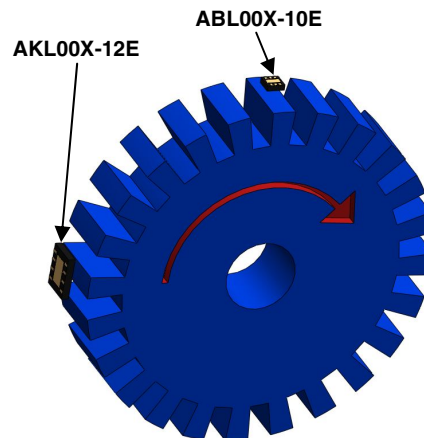

**Figure 2. Sensor orientation.**

### *Recommended sensor element spacing vs. gear pitch*

Optimal sensor element spacing depends on a number of factors, including gear pitch, magnet, and sensor spacing. A rule of thumb is to select a sensor with an element spacing of approximately one-fourth the gear pitch. For example, for a gear pitch of 1 mm, the optimal element spacing would be 0.25 mm. Therefore a sensor with a 0.3 mm spacing, the closest available, would be selected.

**Sinusoidal output with rotation**

As shown in Figure 3 below, a biasing magnet provides a field, and the magnetic flux lines are deflected into the direction of sensitivity by passing metal gear teeth. Sensors are placed between the magnet and gear teeth. Thus the sensor produces a sinusoidal output with one cycle per tooth.

Dual-bridge sensors provide a second bridge output out-of-phase with the first sensor.

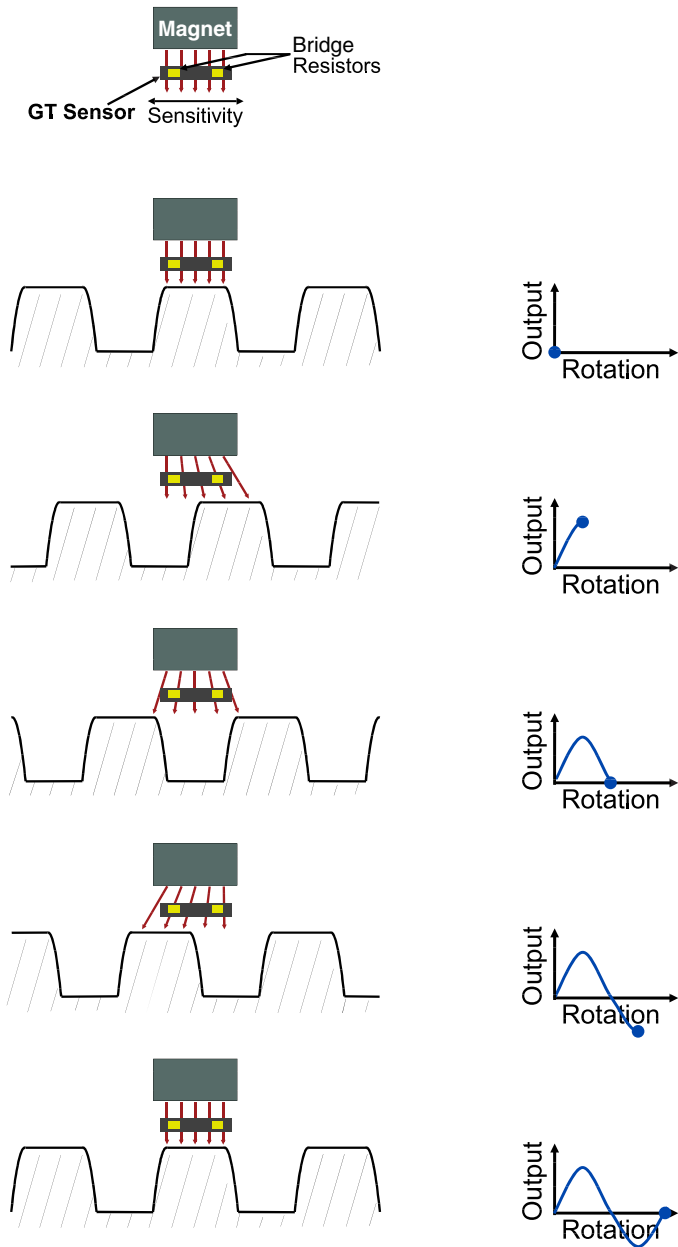

**Figure 3. ABL00x output vs. gear rotation.**

**Typical outputs**

Figures 4 to 6 show typical outputs from each of the three GT Sensor types:

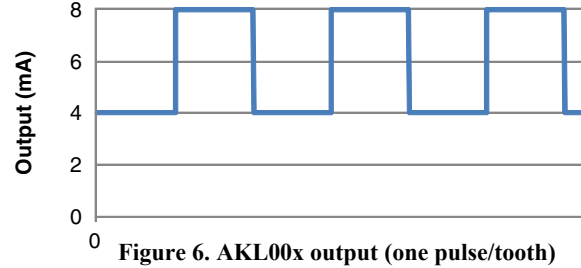
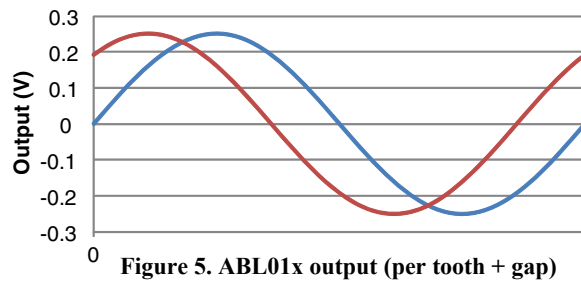
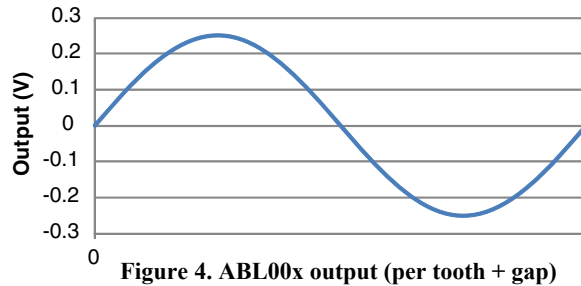

**Illustrative Application Circuits**

**Digital output from analog gear-tooth sensors**

A comparator can be used to provide a digital signal corresponding to each gear passing:

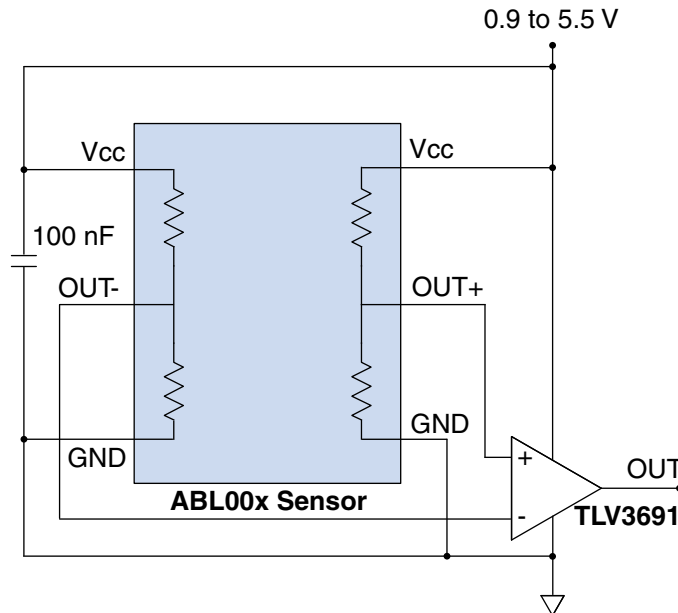
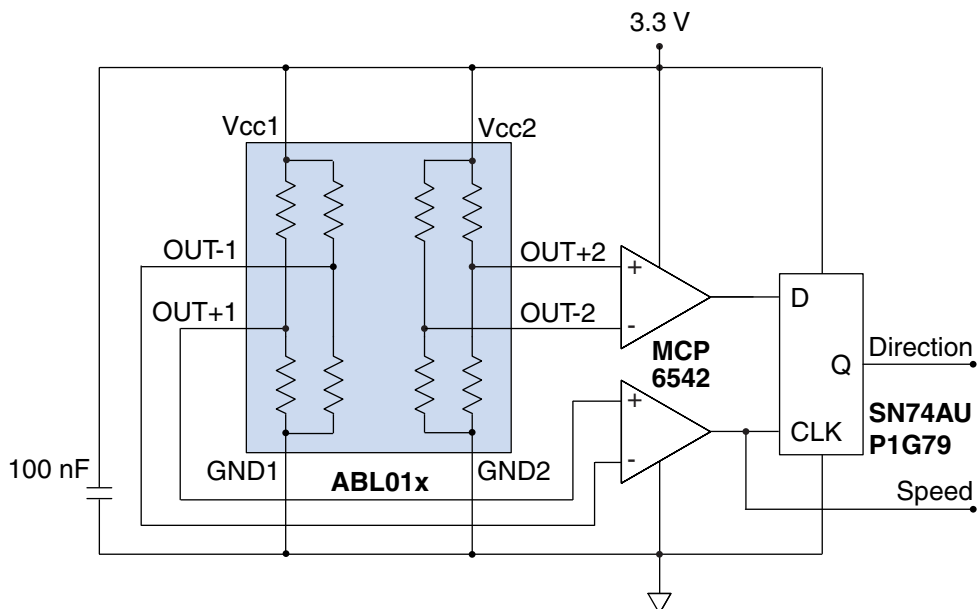

**Figure 7. Digital output from an analog sensor.**

If zero speed operation is not required, AC coupling the sensor remove offset induced by magnetic imperfections.

**Digital Speed and Direction Signals**

ABL01x dual-element sensors provide two outputs that can indicate direction of rotation. A dual comparator and flip-flop can provide direction and speed outputs. Direction is determined by detecting the phasing between the two outputs. The “Speed” output is one cycle per tooth:



**Figure 8. Digital speed and direction signals for gear-tooth sensors.**

**AKL sensor typical operation**

A single resistor in series with the sensor can detect the digital output. A 100Ω resistor provides a 400 mV peak-to-peak signal.

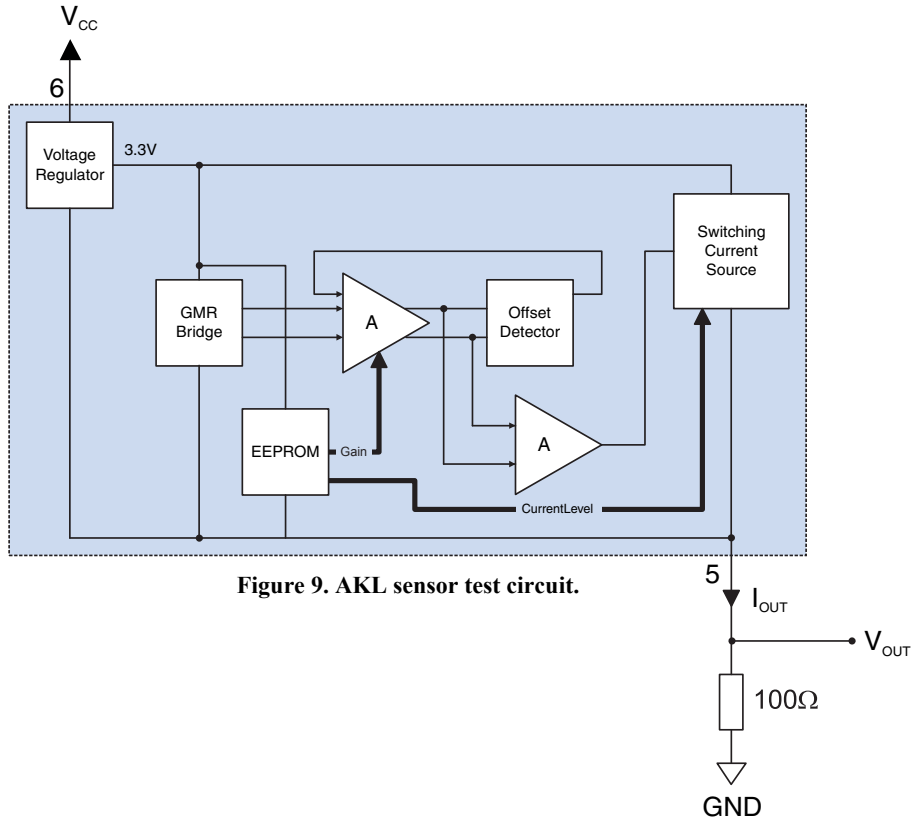

**Figure 9. AKL sensor test circuit.**

**Three-Wire Digital Gear-Tooth Sensor**

The AKL-Series two-wire interface can be easily converted to a three-wire configuration:

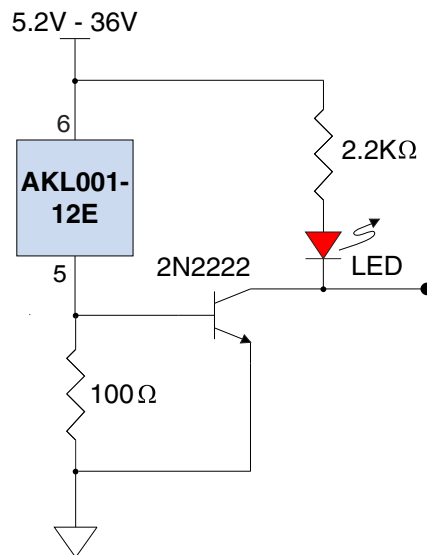
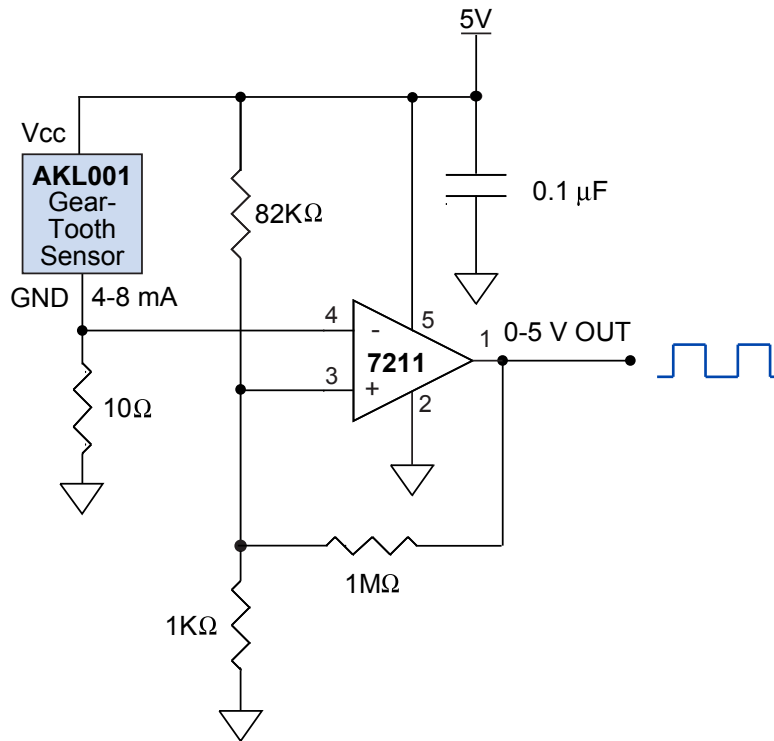

**Figure 10. Simple three-wire interface.**

When the current is 4 mA, the voltage across the 100Ω resistor is 0.4 V, not enough to turn on the transistor. With 8 mA, the transistor turns on. Note that the supply voltage must be at least 5.2 V to provide the sensor's 4.5 V minimum Vcc. The LED is optional.

**TTL Output Gear-Tooth Sensor**

The circuit below uses a simple comparator (7211 or similar) to convert the 4 – 8 mA AKL supply current to a rail-to-rail digital output.

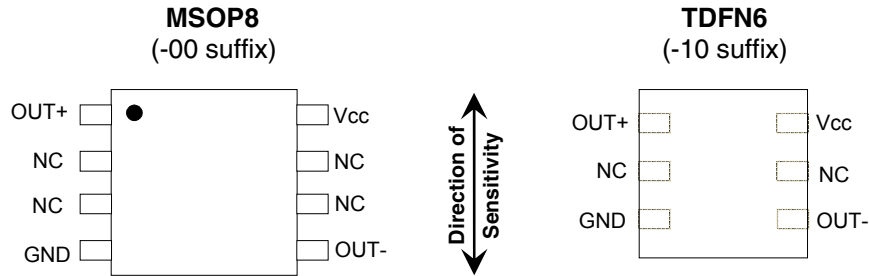

**Figure 11. TTL output gear-tooth sensor.**

The 10Ω series resistor is small enough to ensure the sensor Vcc voltage is above its 4.5 V minimum with a 4.75 – 5.25 V supply. The 1 KΩ and 82 KΩ resistors set a comparator threshold between 4 and 8 mA, and the 1 MΩ resistor provides hysteresis to enhance noise immunity.



**ABL00X-XX (single bridge) pinouts**



Pin		Symbol	Description
MSOP8	TDFN6		
8	6	V <sub>CC</sub>	Power supply
4	3	GND	Ground
1	1	OUT+	Bridge differential output
5	4	OUT-	
2, 3, 6, 7	2, 5	NC	No internal connection

**ABL01X-XX (dual bridge) pinouts**

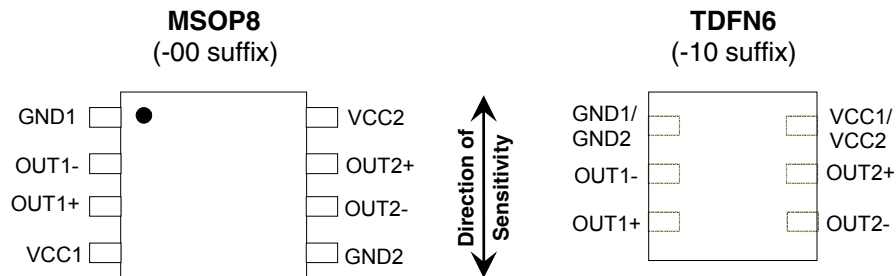

Pin		Symbol	Description
MSOP8	TDFN6		
4	6	V <sub>CC1</sub>	Bridge 1 power supply
8		V <sub>CC2</sub>	Bridge 2 power supply
1	1	GND1	Bridge 1 ground
5		GND2	Bridge 2 ground
2	2	OUT1-	Bridge 1 differential output
3	3	OUT1+	
5	4	OUT2-	Bridge 2 differential output
6	5	OUT2+	

**AKL-Series Pinout**

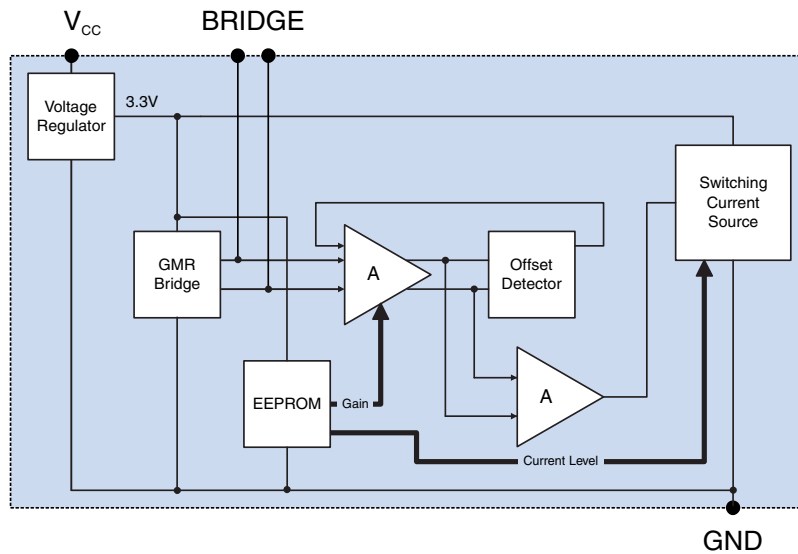

TDFN8 Pin	Symbol	Description
6	V <sub>CC</sub>	Supply voltage
5	GND	Ground
4	BRIDGE+	Bridge outputs (leave floating for normal operation)
7	BRIDGE-	
1, 2, 3, 8	Test	No connections should be made for normal operation

## Available Parts

ABL-Series Analog Gear-Tooth Sensors						
Part No.	Single or Dual Bridge	Element Spacing	Phase Shift Between Bridges	Recommended Gear Pitch	Package	Package Marking Code
ABL004-00	Single	1 mm	NA	2.5 – 6 mm	MSOP8	FDB
ABL005-00	Single	0.5 mm	NA	1.5 – 2.5 mm	MSOP8	FDC
ABL006-00	Single	0.3 mm	NA	0.6 – 1.5 mm	MSOP8	FDL
ABL014-00	Dual	1 mm	0.5 mm	2.5 – 6 mm	MSOP8	FDD
ABL015-00	Dual	0.5 mm	0.25 mm	1.5 – 2.5 mm	MSOP8	FDF
ABL016-00	Dual	0.3 mm	0.15 mm	0.6 – 1.5 mm	MSOP8	FDM
ABL004-10	Single	1 mm	NA	2.5 – 6 mm	TDFN6	FDG
ABL005-10	Single	0.5 mm	NA	1.5 – 2.5 mm	TDFN6	FDH
ABL006-10	Single	0.3 mm	NA	0.6 – 1.5 mm	TDFN6	FDN
ABL014-10	Dual	1 mm	0.5 mm	2.5 – 6 mm	TDFN6	FDJ
ABL015-10	Dual	0.5 mm	0.25 mm	1.5 – 2.5 mm	TDFN6	FDK
ABL016-10	Dual	0.3 mm	0.15 mm	0.6 – 1.5 mm	TDFN6	FDP

AKL-Series Digital Gear-Tooth Sensors			
Part No.	Element Spacing	Recommended Gear Pitch	Package
AKL001-12	1 mm	2.5 – 6 mm	TDFN8
AKL002-12	0.5 mm	1.5 – 2.5 mm	TDFN8
AKL003-12	0.3 mm	0.6 – 1.5 mm	TDFN8

**Package Drawings**

**MSOP8 (-00 suffix)**

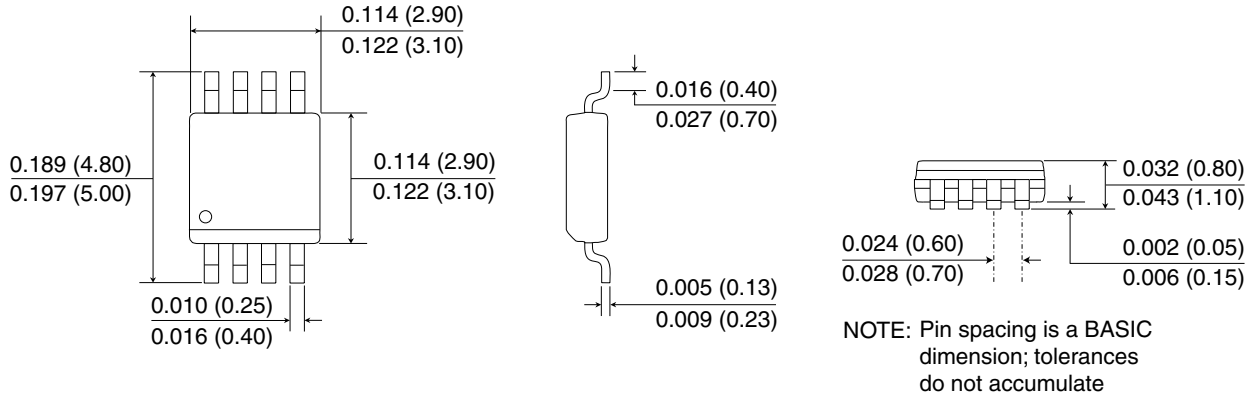

**TDFN6 (-10 suffix)**

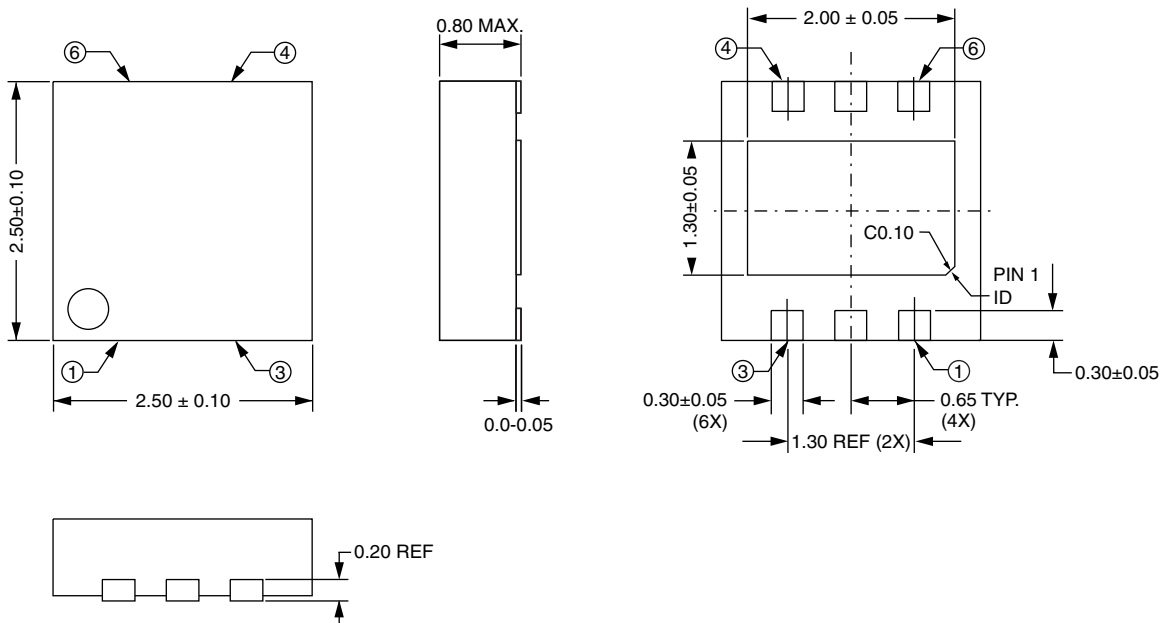

**TDFN8 (-11 suffix)**

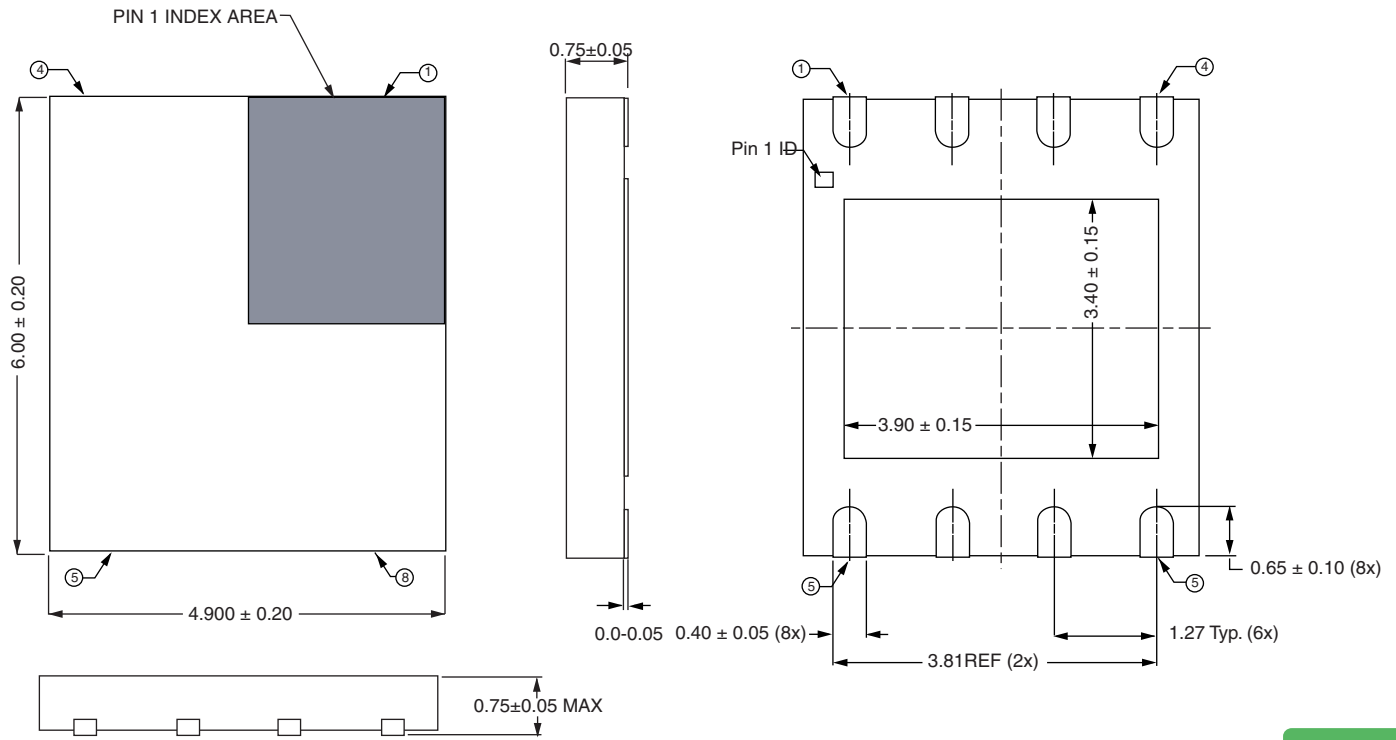

**RoHS**  
COMPLIANT

All soldering profiles per JEDEC J-STD-020C, MSL 1.

## Revision History

---

**SB-00-061-A**  
March 2017

**Change**

- Initial datasheet release superseding catalog.

### **Datasheet Limitations**

The information and data provided in datasheets shall define the specification of the product as agreed between NVE and its customer, unless NVE and customer have explicitly agreed otherwise in writing. All specifications are based on NVE test protocols. In no event however, shall an agreement be valid in which the NVE product is deemed to offer functions and qualities beyond those described in the datasheet.

### **Limited Warranty and Liability**

Information in this document is believed to be accurate and reliable. However, NVE does not give any representations or warranties, expressed or implied, as to the accuracy or completeness of such information and shall have no liability for the consequences of use of such information.

In no event shall NVE be liable for any indirect, incidental, punitive, special or consequential damages (including, without limitation, lost profits, lost savings, business interruption, costs related to the removal or replacement of any products or rework charges) whether or not such damages are based on tort (including negligence), warranty, breach of contract or any other legal theory.

### **Right to Make Changes**

NVE reserves the right to make changes to information published in this document including, without limitation, specifications and product descriptions at any time and without notice. This document supersedes and replaces all information supplied prior to its publication.

### **Use in Life-Critical or Safety-Critical Applications**

Unless NVE and a customer explicitly agree otherwise in writing, NVE products are not designed, authorized or warranted to be suitable for use in life support, life-critical or safety-critical devices or equipment. NVE accepts no liability for inclusion or use of NVE products in such applications and such inclusion or use is at the customer's own risk. Should the customer use NVE products for such application whether authorized by NVE or not, the customer shall indemnify and hold NVE harmless against all claims and damages.

### **Applications**

Applications described in this datasheet are illustrative only. NVE makes no representation or warranty that such applications will be suitable for the specified use without further testing or modification.

Customers are responsible for the design and operation of their applications and products using NVE products, and NVE accepts no liability for any assistance with applications or customer product design. It is customer's sole responsibility to determine whether the NVE product is suitable and fit for the customer's applications and products planned, as well as for the planned application and use of customer's third party customers. Customers should provide appropriate design and operating safeguards to minimize the risks associated with their applications and products.

NVE does not accept any liability related to any default, damage, costs or problem which is based on any weakness or default in the customer's applications or products, or the application or use by customer's third party customers. The customer is responsible for all necessary testing for the customer's applications and products using NVE products in order to avoid a default of the applications and the products or of the application or use by customer's third party customers. NVE accepts no liability in this respect.

### **Limiting Values**

Stress above one or more limiting values (as defined in the Absolute Maximum Ratings System of IEC 60134) will cause permanent damage to the device. Limiting values are stress ratings only and operation of the device at these or any other conditions above those given in the recommended operating conditions of the datasheet is not warranted. Constant or repeated exposure to limiting values will permanently and irreversibly affect the quality and reliability of the device.

### **Terms and Conditions of Sale**

In case an individual agreement is concluded only the terms and conditions of the respective agreement shall apply. NVE hereby expressly objects to applying the customer's general terms and conditions with regard to the purchase of NVE products by customer.

### **No Offer to Sell or License**

Nothing in this document may be interpreted or construed as an offer to sell products that is open for acceptance or the grant, conveyance or implication of any license under any copyrights, patents or other industrial or intellectual property rights.

### **Export Control**

This document as well as the items described herein may be subject to export control regulations. Export might require a prior authorization from national authorities.

### **Automotive Qualified Products**

Unless the datasheet expressly states that a specific NVE product is automotive qualified, the product is not suitable for automotive use. It is neither qualified nor tested in accordance with automotive testing or application requirements. NVE accepts no liability for inclusion or use of non-automotive qualified products in automotive equipment or applications.

In the event that customer uses the product for design-in and use in automotive applications to automotive specifications and standards, customer (a) shall use the product without NVE's warranty of the product for such automotive applications, use and specifications, and (b) whenever customer uses the product for automotive applications beyond NVE's specifications such use shall be solely at customer's own risk, and (c) customer fully indemnifies NVE for any liability, damages or failed product claims resulting from customer design and use of the product for automotive applications beyond NVE's standard warranty and NVE's product specifications.

An ISO 9001 Certified Company

NVE Corporation  
11409 Valley View Road  
Eden Prairie, MN 55344-3617 USA  
Telephone: (952) 829-9217  
Fax: (952) 829-9189  
[www.nve.com](http://www.nve.com)  
e-mail: [sensor-info@nve.com](mailto:sensor-info@nve.com)

©NVE Corporation  
All rights are reserved. Reproduction in whole or in part is prohibited without the prior written consent of the copyright owner.

SB-00-061\_RevA

*March 2017*