

SHIELD01: 40-Volt / 50-Amp H-Bridge Arduino Shield

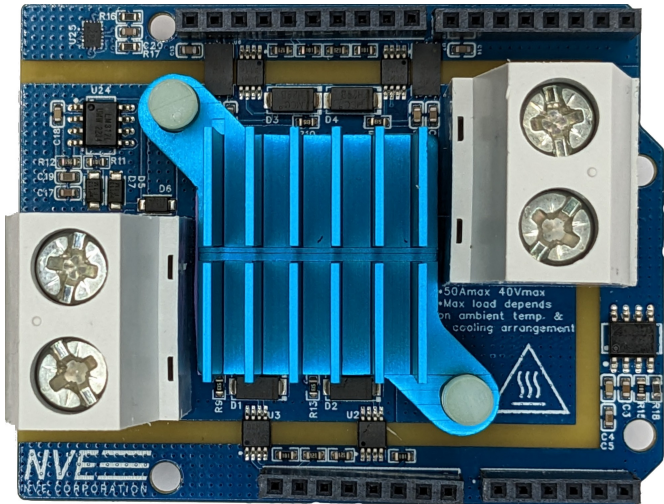

Scan for Arduino programs and more information
<https://github.com/NveCorporation/Arduino-H-bridge-shield>

H-Bridge Shield Overview

Features

- Fully Arduino compatible
- Simple three-wire Arduino interface (PWM, Dir, and Enable)
- Motor control up to 2 kW (2.5 HP)
- Thermal vias and heat-sinking
- Standard Arduino Shield form factor
- Easy connections with large screw terminals
- Arduino example programs available for download

Specifications

- Max. load: 2 kW (40 V / 50 A)
- Load supply line: 8 V to 40 V
- Arduino supply: 7 V to 20 V via power connector or 5V via USB; 500 mA
- Logic-to-load isolation: 2.5 kV_{RMS} per UL 1577
- Rds On: 1.2 mΩ typ. each MOSFET
- Operating Temperature Range: -40 °C to 85 °C
- Dimensions: 2.1 in. by 2.7 in. (53.4 mm by 68.6 mm)

Applications

- Motor speed and direction control
 - Robotics
 - DC-to-AC invertors
-

Quick Start

- ⇒ Connect the Shield board to an Arduino.
- ⇒ Connect the “line side” screw terminals to a motor power supply (8 to 40 V).
- ⇒ Connect the “load side” screw terminals to a motor.
- ⇒ Scan the QR Code on the front cover to download an example Arduino program from the NVE GitHub repository.
- ⇒ Run the Arduino program.
- ⇒ Modify the Arduino program for your application.

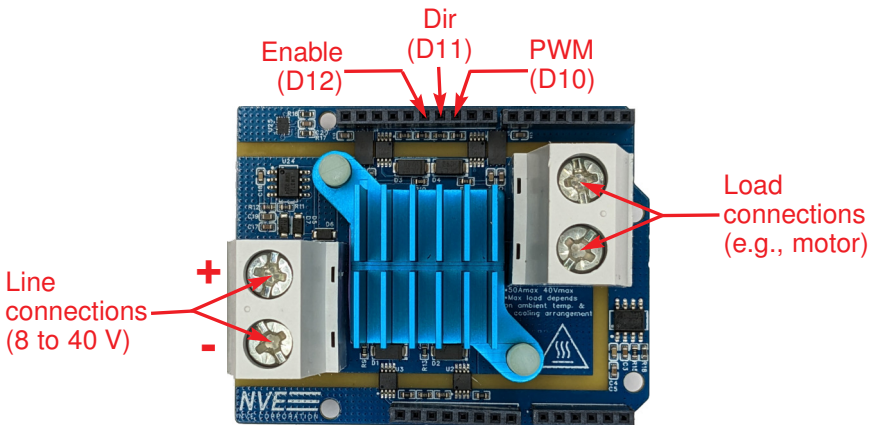

Precautions

- ⚠ Warning!** The heatsink and certain components may become hot during operation. Do not touch.
 - ⚠ Caution!** Inductive surges can cause MOSFET voltages to exceed the motor supply voltage. Allow adequate margin to avoid damaging the MOSFETs.
 - ⚠ Caution!** Disable the control (set enable LOW) while reversing direction to avoid damaging the MOSFETs.
-

Schematic

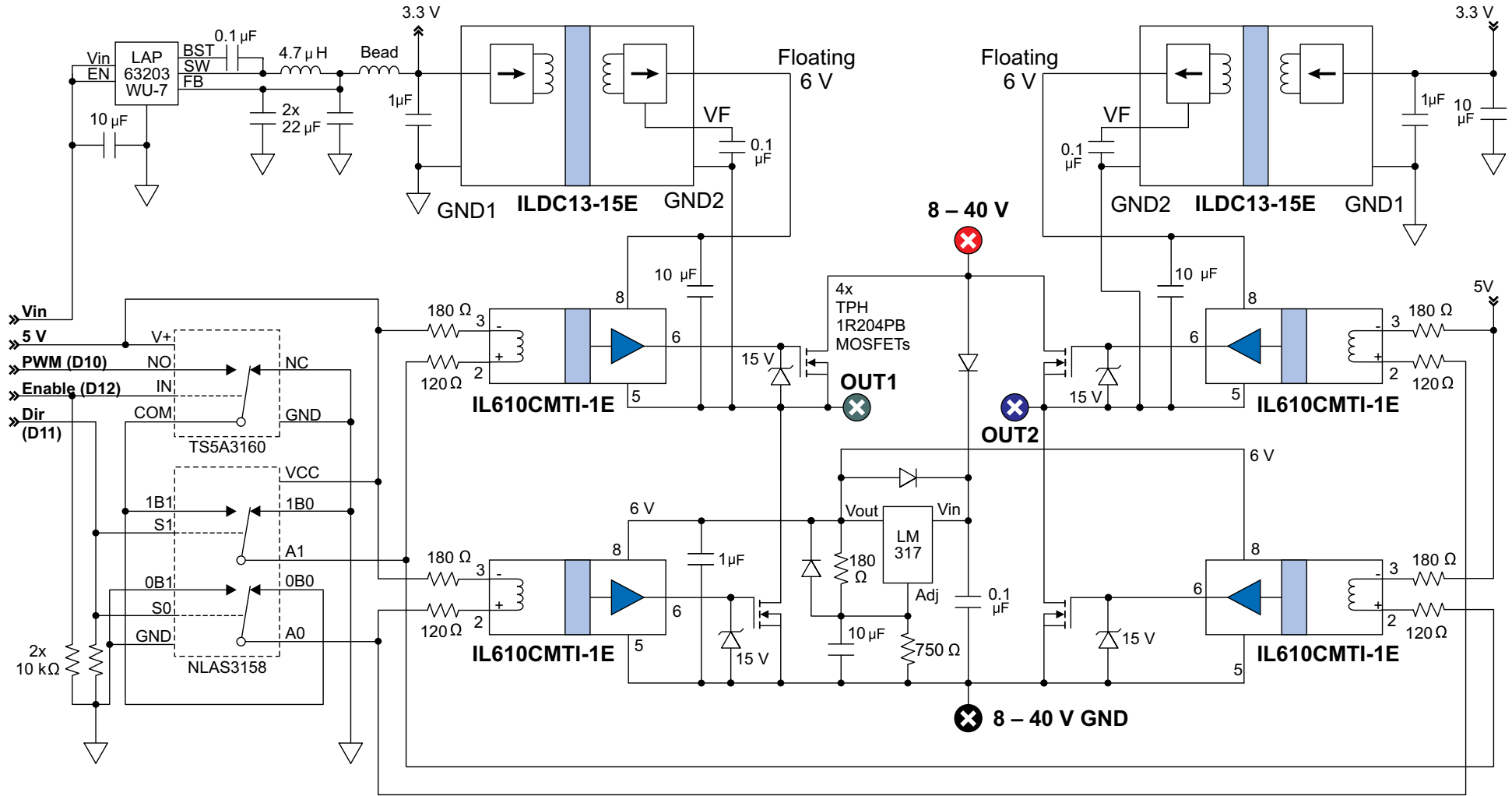

Circuit Description

The heart of the H-bridge Arduino Shield is four power MOSFETs, four ultrahigh CMTI isolated MOSFET drivers, and two ultraminiature isolated DC-to-DC convertors.

The two low-side IL610CMTI-1E isolators level-shift the Arduino outputs to six volts to drive the low-side MOSFETs. The high-side isolators drive the high-side MOSFETs, as the MOSFET source voltages float with the load. The two ILDC13-15E DC-to-DC convertors generate floating six-volt supplies referenced to the MOSFET source pins to power the high-side isolator/gate drivers.

The isolators have extremely high Common-Mode Transient Immunity (CMTI), so they do not glitch even when MOSFET source-pin voltages change rapidly as the MOSFETs switch. The resistors in series with the isolator input coils set the input current to approximately 12 mA. The resistor values maximize CMTI.

The NLAS3158 analog switch provides PWM and Direction inputs for a simple Arduino interface. The switch's short break-before-make time prevents two MOSFETs on the same side being on at the same time ("shoot-through"). The TS5A3160 analog switch provides an Enable line, allowing all four MOSFETs to be disabled such as during a reversal. The 10 k Ω pull-down resistors ensure the load is disabled until the Arduino powers up and provides outputs.

The AP63203WU-7 buck regulator provides 3.3 volts to power the DC-to-DC convertors and supports the Arduino's 20 V maximum input voltage; a linear regulator could be used for lower input voltages. A ferrite bead, optimized for the 113 MHz convertor frequency, mitigates DC-to-DC convertor EMI.

An LM317 regulator provides six volts from the line input supply to power the low-side gate drivers. The LM317 circuit includes diodes for short-circuit and reverse voltage protection.

Zener diodes protect the MOSFET gates from overvoltage. The MOSFET and LM317 ratings limit the maximum line input supply to 40 volts. The Shield's 50-amp drive current specification is set by PCB trace and thermal limitations; the MOSFETs are rated to 150 amps.

Bill of Materials

Qty	Designator	Part Number	Mfr	Description
2	U6,U7	ILDC13-15E	NVE	Ultramini Isolated 1/4W 3.3-6V DC-DC Conv
4	U2,U3,U4,U8	IL610CMTI	NVE	1-Ch Ultrahigh CMTI Isolator, 2.5 kV, MSOP
4	M1,M2,M3,M4	TPH1R204PB,L1Q	Toshiba	MOSFET N-CH 40V 150A SSOP
1	U28	AP63203WU-7	Diodes	IC REG BUCK 3.3V 2A TSOT26
1	U5	NCV317MBSTT3G	onsemi	IC REG LIN POS ADJ 500MA SOT223
1	U19	NLAS3158MNR2G	onsemi	IC SWITCH SPDT X 2 130HM 12DFN
1	U27	TS5A3160DCKR	TI	IC SWITCH SPDTX1 900MOHM SC70-6
1	x	ATS-CPX025025020	ATS	HEATSINK 25X25X20MM L-TAB CP
1	x	TG-A4500-25-25-1.0	t-Global	THERM PAD 25MMX25MM PURP
1	x	ATS-HK127-R0	ATS	HEATSINK PLASTIC PIN/SPRING 1=2
3	D5-D7	F1M	Yangjie	DIODE GEN PURP 1KV 1A SOD123FL
4	D1-D4	3SMAJ15929B-TP	MCC	DIODE ZENER 15V 3W DO214AC
2	H1,H2	691256610002	Würth	TERM BLK 2P SIDE ENT 10.16MM PCB
1	H4	SSW-106-03-T-S	Samtec	CONN RCPT 6POS 0.1 TIN PCB
2	H3,H6	SSW-108-03-T-S	Samtec	CONN RCPT 8POS 0.1 TIN PCB
1	H7	SSQ-110-03-T-S	Samtec	CONN RCPT 10POS 0.1 TIN PCB
4	R2,R4,R6,R8	RMCF0603JG120R	Stackpole	RES 120 OHM 5% 1/10W 0603
5	R1,R3,R5,R7,R11	RMCF0603JT180R	Stackpole	RES 180 OHM 5% 1/10W 0603
4	R9,R10,R13,R14	RMCF0603JT51K0	Stackpole	RES 51K OHM 5% 1/10W 0603
2	R16,R17	RMCF0603JT10K0	Stackpole	RES 10K OHM 5% 1/10W 0603
1	R12	RMCF0603JT750R	Stackpole	RES 750 OHM 5% 1/10W 0603
4	C8,C9,C18,C30	CL10B104KC8NNNC	Samsung	0.1 μ F \pm 10% 100V Cer Cap X7R 0603
5	C1-2,C6,C12,C17	CL10A105KB8NNNC	Samsung	1 μ F \pm 10% 50V Cer Cap X5R 0603
4	C19,C28,C29,C33	CL10A106MA8NNRC	Samsung	10 μ F \pm 20% 25V Cer Cap X5R 0603
2	C31,C32	CL21A226MQ0NNNG	Samsung	22 μ F \pm 20% 6.3V Cer Cap X5R 0805
1	L5	SDEM25201B-4R7MS	Delta Elec	FIXED IND 4.7UH 1.6A 240MOHM SMD
1	L6	BBPY00100505102Y00	Murata	600 Ohms @ 100 MHz Ferrite Bead 0402

IL61xCMTI: Ultrahigh CMTI Isolated MOSFET Drivers

- 200 kV/ μ s guaranteed CMTI; 300 kV/ μ s with deglitch circuitry
- Extended 3 to 6.6 volt power supply range
- 2.5 kV isolation
- Single- and dual-channel configurations
- 8-pin MSOP and SOIC packages

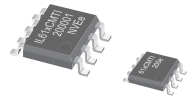

ILDC1x: Ultraminiature Isolated DC-to-DC Converters

- World's smallest isolated DC-to-DC converters
- Ultraminiature 3 x 5.5 x 0.9 mm DFN or 8 mm creepage SOIC16-WB
- 3.3 volt input; 3.3, 5, or 6 volt output options
- ¼ watt, fully-regulated output
- No minimum load
- 2.5 kV or 4 kV isolation
- -40 °C to 125 °C with no derating

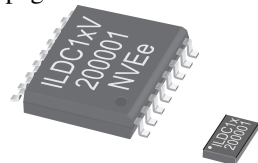

Limited Warranty and Liability

Information in this document is believed to be accurate and reliable. However, NVE does not give any representations or warranties, expressed or implied, as to the accuracy or completeness of such information and shall have no liability for the consequences of use of such information. In no event shall NVE be liable for any indirect, incidental, punitive, special or consequential damages (including, without limitation, lost profits, lost savings, business interruption, costs related to the removal or replacement of any products or rework charges) whether or not such damages are based on tort (including negligence), warranty, breach of contract or any other legal theory.

Right to Make Changes

NVE reserves the right to make changes to information published in this document including, without limitation, specifications and product descriptions at any time and without notice.

Use in Life-Critical or Safety-Critical Applications

Unless NVE and a customer explicitly agree otherwise in writing, NVE products are not designed, authorized or warranted to be suitable for use in life support, life-critical or safety-critical devices or equipment. NVE accepts no liability for inclusion or use of NVE products in such applications and such inclusion or use is at the customer's own risk. Should the customer use NVE products for such application whether authorized by NVE or not, the customer shall indemnify and hold NVE harmless against all claims and damages.

Applications

Applications described in this document are illustrative only. NVE makes no representation or warranty that such applications will be suitable for the specified use without further testing or modification. Customers are responsible for the design and operation of their applications and products using NVE products, and NVE accepts no liability for any assistance with applications or customer product design. It is customer's sole responsibility to determine whether the NVE product is suitable and fit for the customer's applications and products planned, as well as for the planned application and use of customer's third party customers. Customers should provide appropriate design and operating safeguards to minimize the risks associated with their applications and products. NVE does not accept any liability related to any default, damage, costs or problem which is based on any weakness or default in the customer's applications or products, or the application or use by customer's third party customers. The customer is responsible for all necessary testing for the customer's applications and products using NVE products in order to avoid a default of the applications and the products or of the application or use by customer's third party customers. NVE accepts no liability in this respect.

An ISO 9001 Certified Company

NVE Corporation
11409 Valley View Road
Eden Prairie, MN 55344-3617

Part No.: SHIELD01-01
Manual No.: ISB-DS-001-SHIELD01-01

©NVE Corporation

All rights are reserved. Reproduction in whole or in part is prohibited without the prior written consent of the copyright owner.