



# **IsoLoop<sup>®</sup> Isolation Products**

## ***Illustrative Applications***

- **Isolated RS-485/PROFIBUS**
- **Isolated CANbus**
- **Isolated ADCs and DACs**
- **Isolated Serial Interfaces**
- **Isolated Power Interfaces**

# Isolated RS-485/PROFIBUS



## Single-Chip RS-485/PROFIBUS Isolated Transceivers

NVE offers the industry's broadest line of single-chip isolated RS-485 transceivers, including digital and passive input versions, fractional-load versions, and PROFIBUS-compliant versions. Termination resistors can be added to maximize speed and transmission length. Fail-safe resistors guarantee a known state on a terminated bus with no active transceivers. NVE transceivers are available with data rates up to 40 Mbps. Parts are available in 0.3" and 0.15" 16-pin SOIC packages.

IsoLoop logic isolators can also be used as part of multi-chip designs to isolate signals using particular non-isolated transceivers (see examples below).

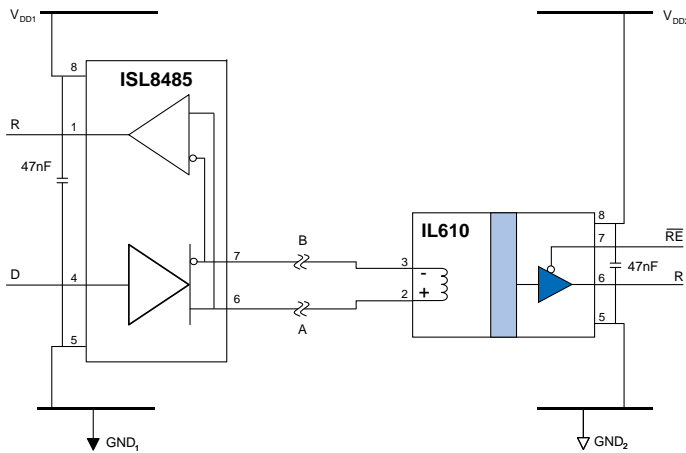
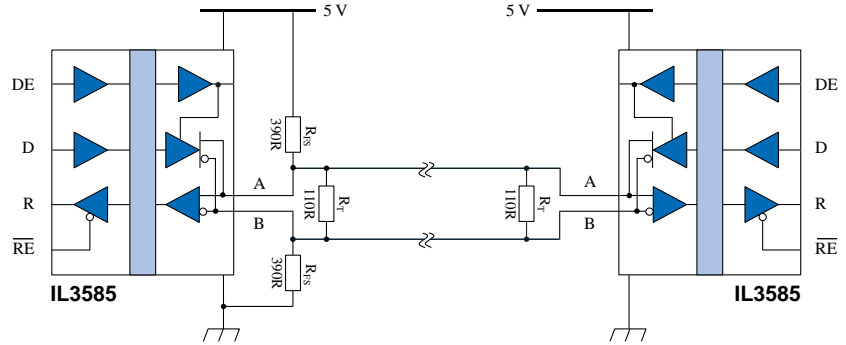

## Single-Component RS-485 Receiver Using IL610

An IL610 can be used as a simple isolated RS-485/RS-422 receiver. No external resistors are required, and cabling is greatly simplified by eliminating the need to power the input side of the receiving board. The circuit is failsafe because the IL610 is guaranteed to switch to the high state when the coil input current is less than 500  $\mu$ A. No current-limiting resistor is needed for a single receiver because it will draw less current than the driver maximum. There is also no need for line termination resistors in most IL610 line receiver applications below a data rate of about 10 Mbps because the IL610 coil resistance of approximately 70 Ohms is close to the characteristic impedance of most cables.

A unique IL610 MSOP is available for space-critical boards.

## Isolated Fractional Load RS-485 Using IL614

NVE offers a broad line of single-chip isolated RS-485 transceivers, but the unique IL614 three-channel isolator can also be used as part of a multi-chip design with non-isolated transceivers. The IL614 provides 2.5 kV<sub>RMS</sub> isolation (1 minute) and 20 kV/ $\mu$ s transient immunity. The IL614-3 is in a narrow-body (0.15"-wide) package when board space is critical.

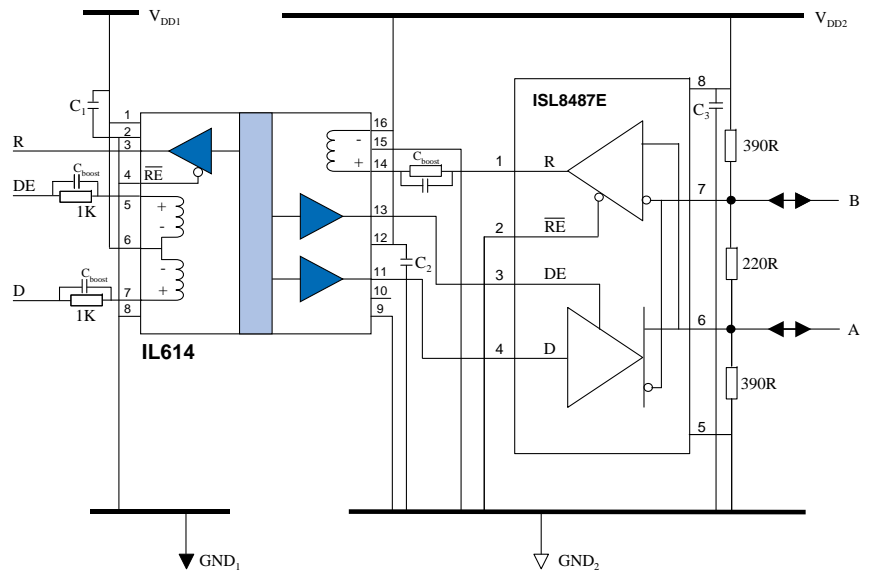

# Isolated Controller Area Network



## Isolating Standard CAN Transceivers

Isolating CAN allows higher bus speed and more reliable operation by eliminating ground loops and reducing susceptibility to noise and EMI. This simple circuit works with any CAN transceiver with a TxD dominant timeout, which includes all of the current-generation transceivers, such as the ubiquitous Philips/NXP TJA1050.

The IL700's best-in-class propagation delay of 10 ns minimizes CAN loop delay and maximizes data rate over any given bus length.

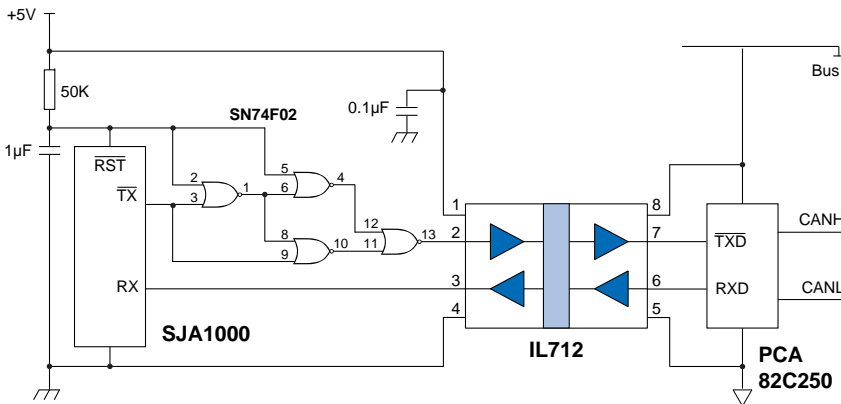
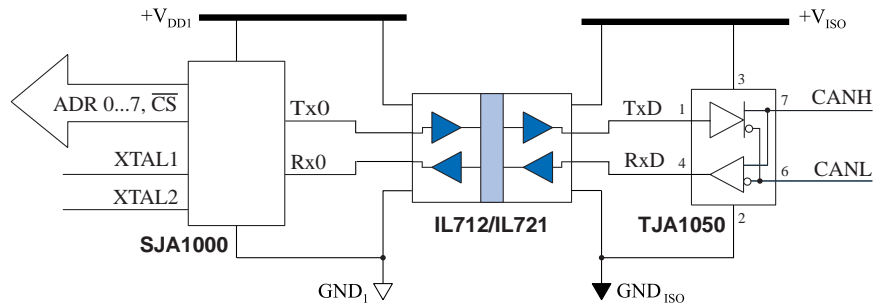

## Isolating Legacy CAN Transceivers

Power-on reset circuitry allows an IL712 to isolate legacy transceivers that lack integrated TxD timeout, such as the Philips/NXP PCA82C250.

# Isolated A/D and D/A Converters

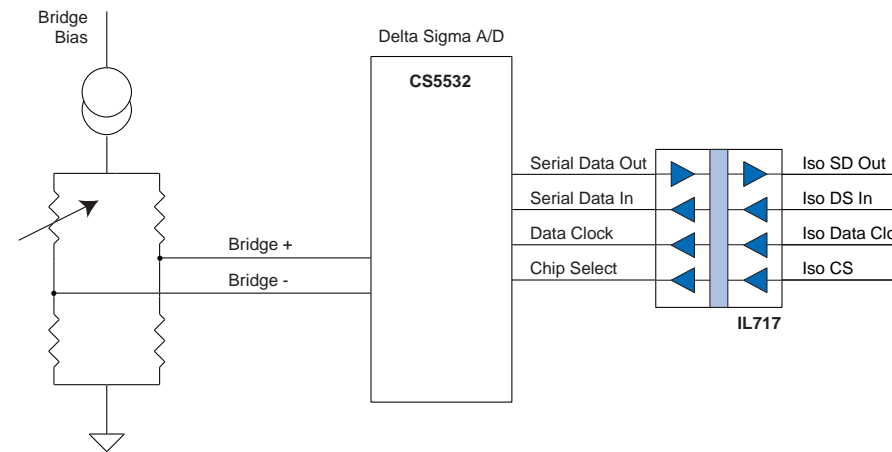
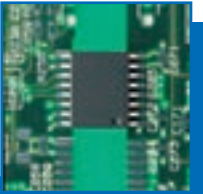

## Single-Channel Isolated SPI Delta-Sigma A/D Converter Using IL717

This circuit illustrates a typical single-channel delta-sigma isolated ADC SPI interface. The A/D is located on the bridge with no signal conditioning electronics between the bridge sensor and the ADC. In this case, the IL717 is the best choice for isolation. It isolates the control bus from the microcontroller. The system clock is located on the isolated side of the system.

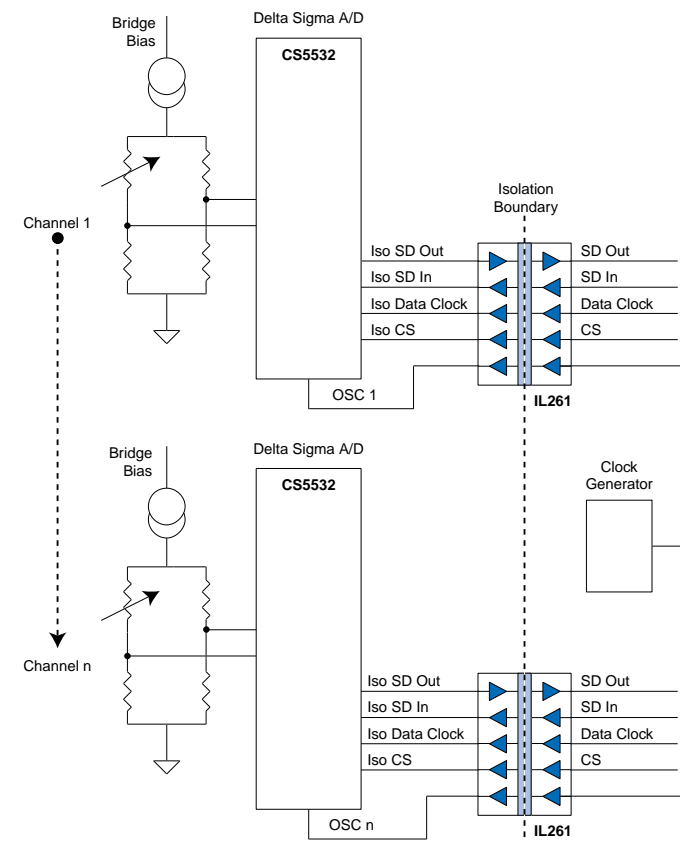

## Multi-Channel Isolated Delta-Sigma A/D Converter Using IL261s

This circuit illustrates multiple ADCs configured in a channel-to-channel isolation configuration. The problem for designers is how to control clock jitter and edge placement accuracy of the system clock for each ADC. The best solution is to use a single clock on the system side and distribute this to each ADC. The IL261 adds a fifth channel to the IL717. This fifth channel is used to distribute a single, isolated clock to multiple ADCs.

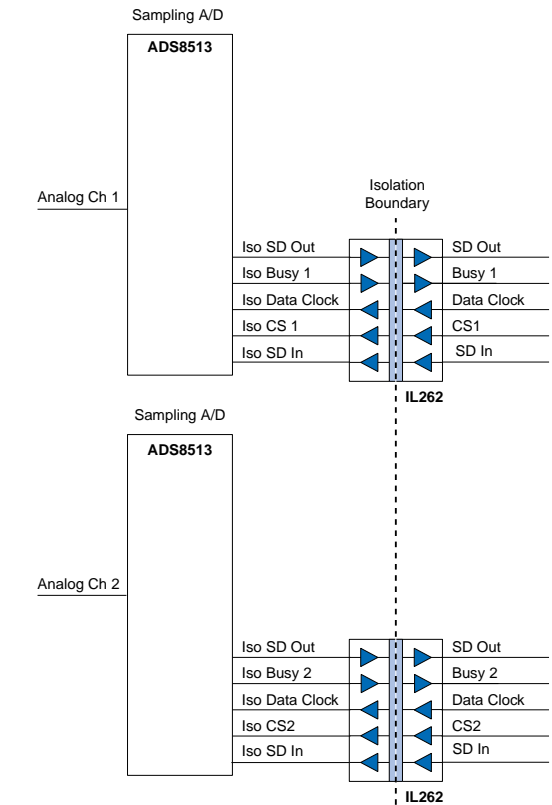

## Isolated Multi-Channel A/D Sampling With IL262s

A multi-channel sampling system with separate A/D cells. The IL262 is used to control the SPI lines and send back ADC BUSY commands to the host, allowing efficient interrupt-driven sampling. The BUSY line may also be used as a Frame Synchronization signal in video applications.

## Multi-Channel Isolated Sampling A/D Converter Using IL261

The IL261 is ideal for isolating multi-channel sampling ADCs. Isolated channels A0 and A1 control the analog channel being sampled, while the three remaining I/O lines on the IL261 isolate the SPI interface.

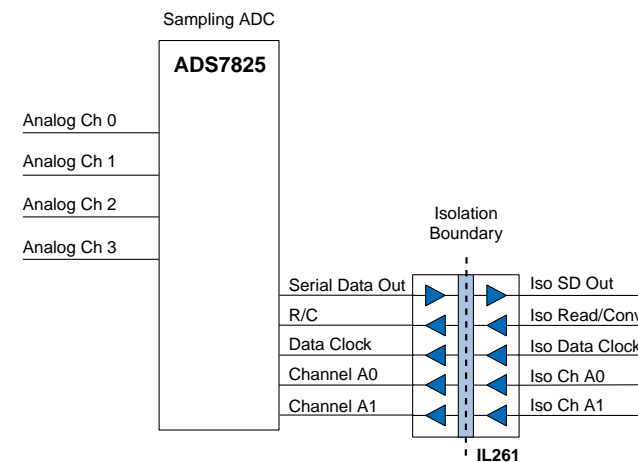

## Isolated Audio DAC Using Two IL260s

Isolation ensures the best DAC performance by eliminating much of the digital noise that tends to find its way onto the analog output. The unique five-channel IL260 isolator series allows ten channels of isolation with just two narrow-body or wide-body ICs.

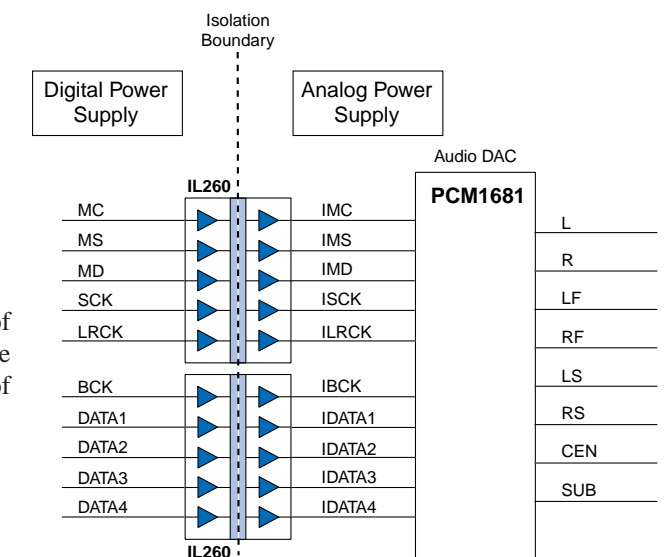

# Isolated Serial Interfaces

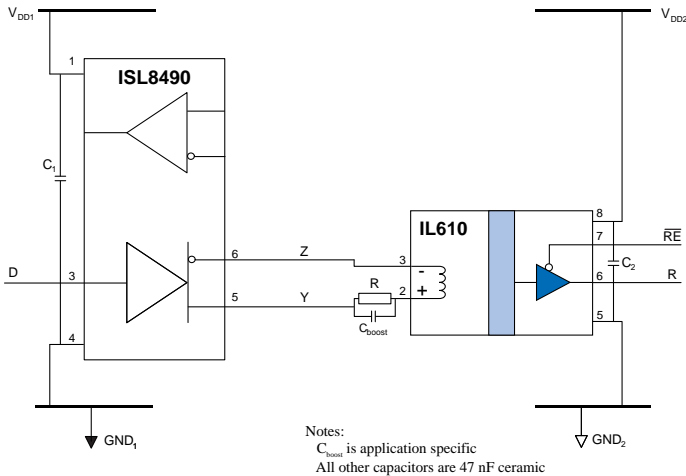

## RS-422 Receiver Using IL610

An IL610 can be used as a simple isolated RS-422 receiver. Cabling is greatly simplified by eliminating the need to power the input side of the receiving board. A similar circuit can be used for RS-485 networks.

The IL610 provides 2500  $V_{RMS}$  isolation (one minute), and 20  $kV/\mu s$  transient immunity. The IL610-1 is a unique MSOP isolator for space-critical boards.

## Isolated I<sup>2</sup>C Using IL612A

This circuit provides bidirectional isolation of I<sup>2</sup>C bus signals with no restrictions on data rate and none of the I<sup>2</sup>C bus latch-up problems common with other isolation circuits.

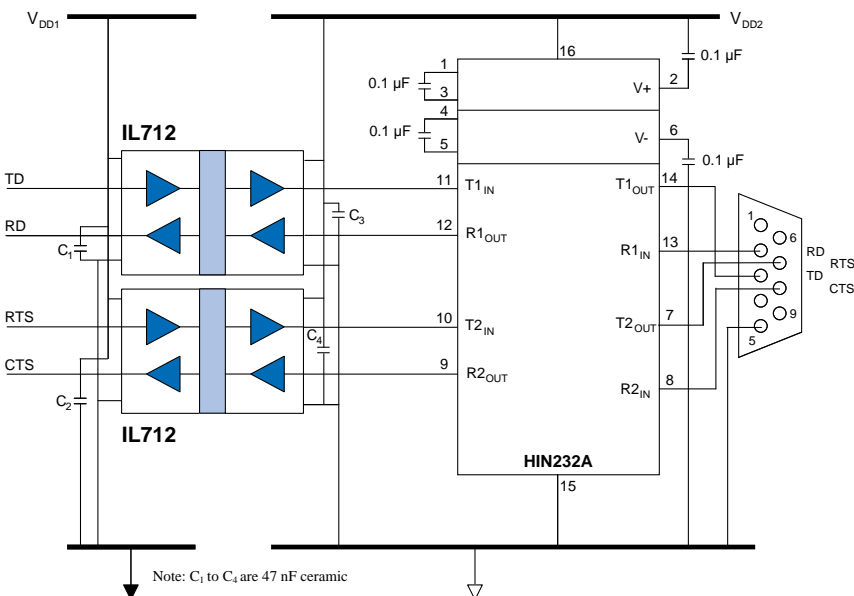
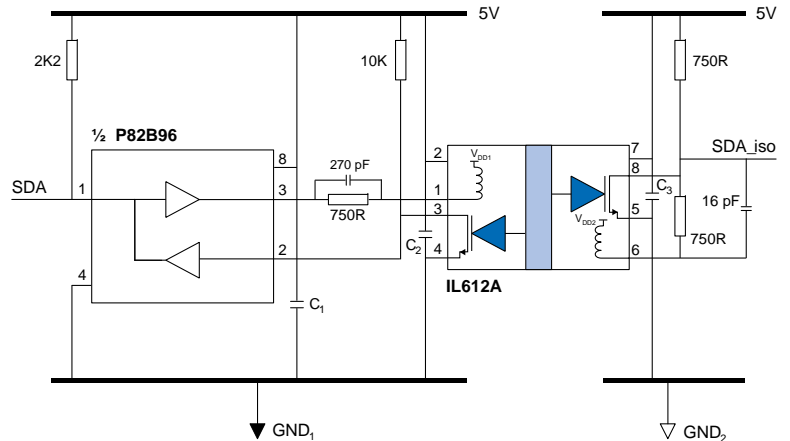

## Isolated RS-232 Using IL712s

IL712s provide 2500  $V_{RMS}$  isolation (one minute) and 30  $kV/\mu s$  typical common-mode transient immunity.

The IL712-1 is a unique eight-pin MSOP dual-channel isolator to shrink board space.

# Isolated Power Interfaces

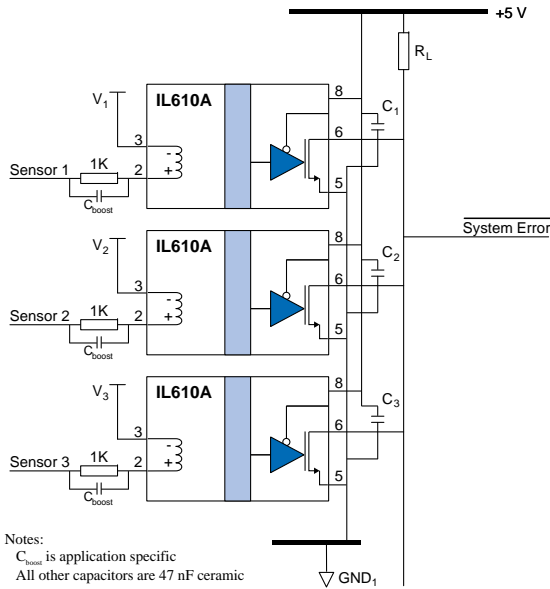

## Multi-channel Isolated Alarm Monitor Using IL610As

IL600A-Series Isolators' open-drain outputs can be wire-OR connected. Inputs can be configured for inverting or non-inverting operation, and a very wide input voltage range is possible. This illustrative circuit using IL610As to provide a fail-safe output (logic high output for zero coil current), 2500 V<sub>RMS</sub> isolation, and 20 kV/ $\mu$ s transient immunity. Typical logic output sink current is 10 mA for each isolator. Unlike optocouplers, IsoLoop Isolators do not degrade over time and have unlimited life.

## Isolated Power Control Using IL610s

The fail-safe output (logic high output for zero coil current) of IL610 Isolators ensures the power FETs will be off on power-up. The IL610 inputs can be configured for inverting or non-inverting operation (see the IL600 Product Data Sheet). IL600-Series Isolators provide 2500 V<sub>RMS</sub> isolation (one minute), and 20 kV/ $\mu$ s transient immunity.

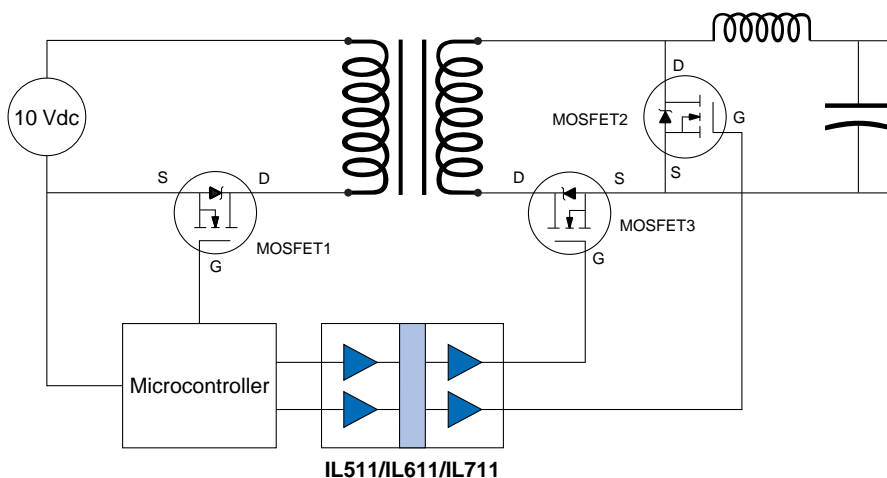
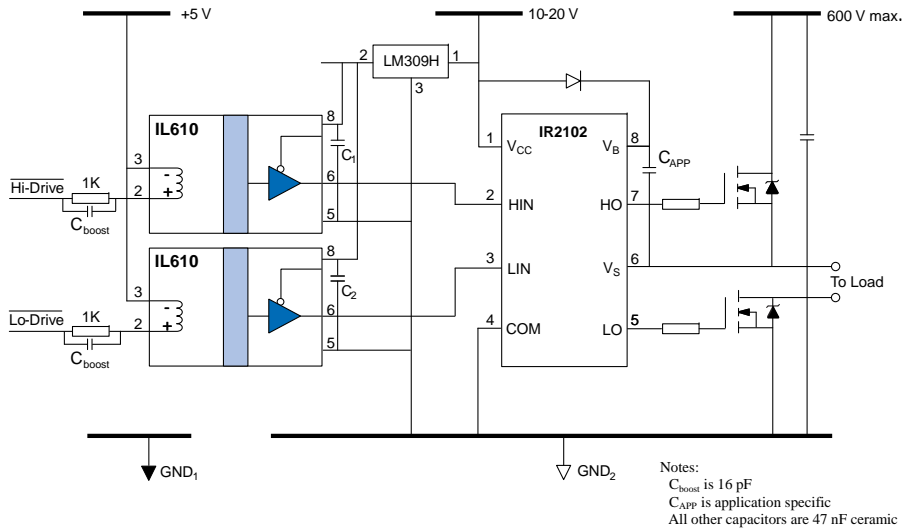

## Intelligent DC-DC Converter With Synchronous Rectification

A typical primary-side controller uses a IL511, IL611 or IL711 isolator to drive the synchronous rectification signals from primary side to secondary side. IsoLoop pulse-width distortion as low as 0.3 ns typical minimizes MOSFET dead time and maximizes system efficiency. Ultra-small isolator packages (including two-channel MSOP-8s), allow the designer to squeeze more into less board area.



**Visit [www.IsoLoop.com](http://www.IsoLoop.com)**

NVE's Website has more illustrative IsoLoop Isolator applications. NVE customers are constantly finding new, innovative applications for these remarkable devices.

## **About NVE**

An ISO 9001 Certified Company

NVE Corporation manufactures innovative products based on unique spintronic Giant Magnetoresistive (GMR) technology. Products include Magnetic Field Sensors, Magnetic Field Gradient Sensors (Gradiometers), Digital Magnetic Field Sensors, Digital Signal Isolators, and Isolated Bus Transceivers.

NVE pioneered spintronics and in 1994 introduced the world's first products using GMR material, a line of ultra-precise magnetic sensors for position, magnetic media, gear speed and current sensing.

NVE Corporation  
11409 Valley View Road  
Eden Prairie, MN 55344-3617 USA  
Telephone: (952) 829-9217  
Fax: (952) 829-9189  
Internet: [www.nve.com](http://www.nve.com)  
e-mail: [iso-info@nve.com](mailto:iso-info@nve.com)

## **Worldwide Distribution**

NVE has a worldwide network of expert distributors ready to assist you. Visit the "Isolator Sales" section of [www.nve.com](http://www.nve.com) for the nearest distributor.

*The information provided by NVE Corporation is believed to be accurate. However, no responsibility is assumed by NVE Corporation for its use, nor for any infringement of patents, nor rights or licenses granted to third parties, which may result from its use. No license is granted by implication, or otherwise, under any patent or patent rights of NVE Corporation. NVE Corporation does not authorize, nor warrant, any NVE Corporation product for use in life support devices or systems or other critical applications, without the express written approval of the President of NVE Corporation.*

Specifications are subject to change without notice.

ISB-CB-002-03C  
January 2010