

1.5-Volt Medical-Grade Magnetic Switch Sensors

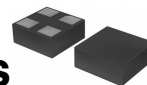

Functional Diagrams

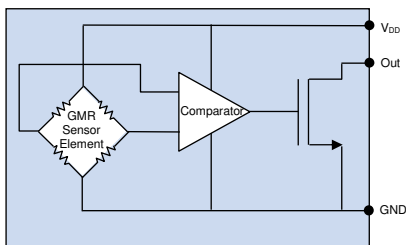

BD9xx / BHK9xx
(continuous duty)

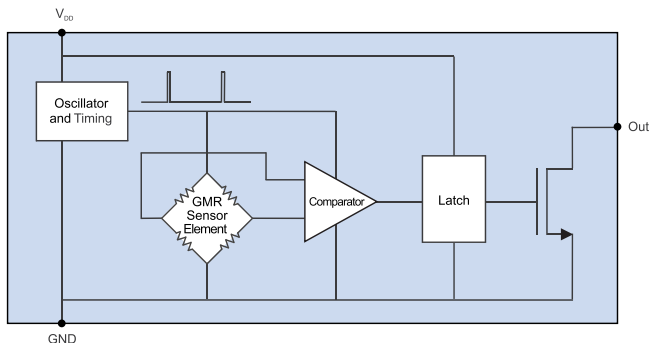

BD0xx
(duty-cycled)

Magnetic Response

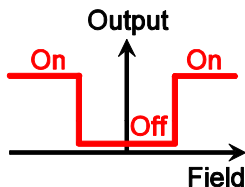

Features

- Sensitive operate points as low as 1.5 mT
- Low hysteresis to prevent magnetic latching
- 0.9 V to 2.4 V operating voltages
- Power as low as 29 nW
- Omnipolar; optional omnidirectional
- 1.1 x 1.1 mm DFN4 package

Applications

- Implantable medical devices
- Continuous glucose monitoring
- Endoscope power switch
- Medical instruments
- Hearing aids

Description

BD-Series sensors are medical-grade Giant Magnetoresistive (GMR) magnetic switches manufactured with NVE's patented spintronic GMR technology for unmatched miniaturization, sensitivity, precision, and low power.

The output connects to ground when the magnetic field is applied. The outputs can sink up to 100 microamps.

A variety of operating points as well as custom operate points are available. The applied field can be of either polarity, and the operate points are extremely stable over supply voltage and temperature.

MRI-correct versions are available that are guaranteed to provide correct outputs in fields up to 3 tesla. All part types can withstand magnetic fields up to 9 tesla without damage.

The products consist of a GMR or TMR sensor element, CMOS signal processing circuitry to convert the analog sensor element output to a digital output, and an oscillator and timing circuit for duty cycling. Continuous-duty, high-speed versions with no oscillator are also available.

Absolute Maximum Ratings

Parameter	Min.	Max.	Units
Supply voltage		5.5	Volts
Output voltage		5.5	Volts
Output current		200	μ A
Storage temperature	-65	170	$^{\circ}$ C
Junction temperature		170	$^{\circ}$ C
ESD (Human-body model)	2000		V
Applied magnetic field		Unlimited	Tesla

Operating Specifications

-40°C to 85°C and V_{DD-MIN} to V_{DD-MAX} unless otherwise stated.								
Parameter	Symbol	Min.	Typ.	Max.	Units	Condition	Comment	
Supply voltage ¹	V_{DD}				Volts			
BD940-14E and BHK991-14E		0.9		1.8				
Others		0.9		2.4				
Operating temperature	$T_{MIN}; T_{MAX}$	-40		85	°C			
Magnetic operate point	H_{OP}				mT			
BD027-14E		1.1	1.5	1.9				
BD028-14E		1.3	1.6	1.9				
BD032-14E		1.2	1.6	1.9				
BD036-14E		2.2	2.8	3.3				
BD927-14E		1.1	1.5	1.9				
BD940-14E		0.8	1.5	1.8				
BHK991-14E		220	350	440				
Magnetic release point	H_{REL}				mT			
BD027-14E		0.45						
BD028-14E		0.45						
BD032-14E		0.45						
BD036-14E		0.6						
BD927-14E		0.45						
BD940-14E		0.4						
BHK991-14E		200						
Hysteresis	$H_{OP} - H_{REL}$							
BD027-14E		0.025		0.65				
BD028-14E		0.025		0.65				
BD032-14E		0.025		0.65				
BD036-14E		0.05						
BD927-14E		0.025		0.65				
BD940-14E		0.1		1.1				
BHK991-14E		1		50				
Quiescent supply current	I_{DDQ}				μA_{RMS}			
BD0xx-14E			0.032	0.06			$V_{DD} = 0.9 V$	
			0.095	0.15			$V_{DD} = 1.4 V$	
			0.46	0.65			$V_{DD} = 2.4 V$	
BD927-14E			15	35			$V_{DD} = 0.9 V$	
			35	55			$V_{DD} = 1.4 V$	
			75	110			$V_{DD} = 2.4 V$	
BD940-14E			0.2	0.5			$V_{DD} = 0.9V; 25^{\circ}C$	
			0.25	1			$V_{DD} = 1.15V; 25^{\circ}C$	
			0.35	2			$V_{DD} = 1.5V; 25^{\circ}C$	
			0.5	2.5			$V_{DD} = 1.8V; 25^{\circ}C$	
BHK991-14E			1	2			$V_{DD} = 0.9V; 25^{\circ}C$	
			1.4	3			$V_{DD} = 1.15V; 25^{\circ}C$	
			2	4			$V_{DD} = 1.5V; 25^{\circ}C$	
			2.8	7			$V_{DD} = 1.8V; 25^{\circ}C$	

Operating Specifications (...continued)

-40°C to 85°C and V_{DD-MIN} to V_{DD-MAX} unless otherwise stated.							
Parameter	Symbol	Min.	Typ.	Max.	Units	Condition	Comment
Output drive current	I_{OL-ON}	100			μA		
Output low voltage	V_{OL}		0.05	0.2	V	$V_{DD} = 1.25 V$; $I_{OL-ON} = 100 \mu A$	
Output leakage current	I_{OL-OFF}			0.5	nA		
Magnetic switching freq. BD027-14E; BD028-14E; BD032-14E; BD036-14E	f	30	40	60	Hz	$V_{DD} = 0.9 V$	Limited by oscillator frequency
		80	110	160		$V_{DD} = 1.4 V$	
		120	260	375		$V_{DD} = 2.4 V$	
BD940-14E; BHK991-14E				3	kHz	$V_{DD} = 1.8 V$	-3 dB point
BD927-14E			100		kHz		
BD940-14E turn-on time	t_{ON}		25	200	μs	1.8V; 25°C	
Max. field for correct output	B_{MAX}				mT		See Figure 14.
BD032-14E		3000	9000				
BHK991-14E		3000	9000				
Others			40				

Notes:

- 1) Operation from -20°C to -40°C at supply voltages less than 1.0 V may not meet specifications.

Dynamic Current Consumption in Duty Cycled Versions

The BD0xx versions are internally duty cycled with onboard oscillators to reduce power consumption. A bypass capacitor should be used to reduce inrush current spikes when the oscillator switches.

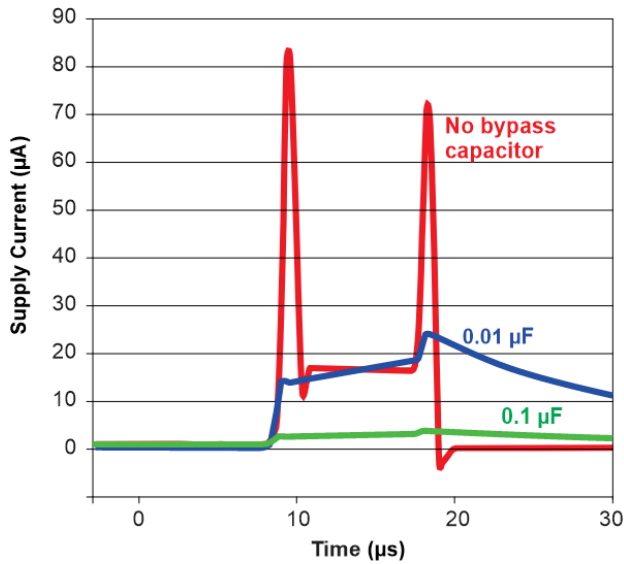

Figure 1. BD0xx-14E supply current
($V_{DD} = 1.2\text{ V}$; with and without bypass capacitors).

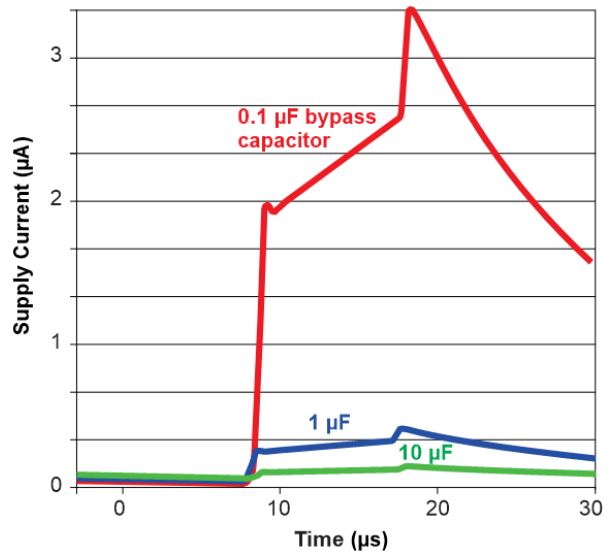

Figure 2. BD0xx-14E supply current
($V_{DD} = 1.2\text{ V}$; various bypass capacitors).

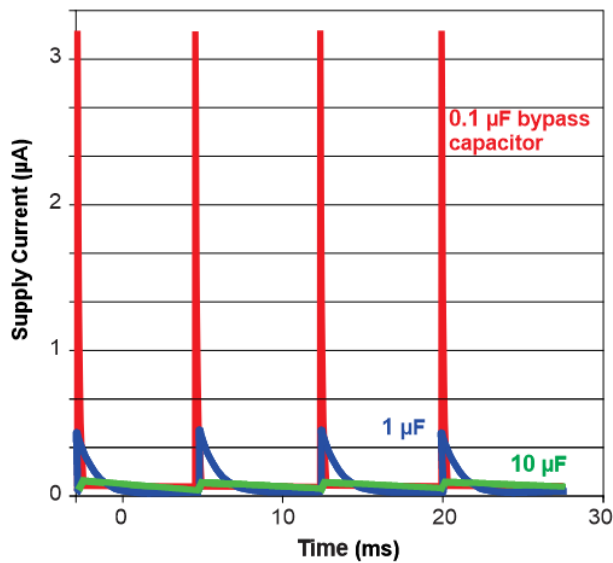

Figure 3. BD0xx-14E supply current
($V_{DD} = 1.2\text{ V}$; various bypass capacitors).

Typical Performance

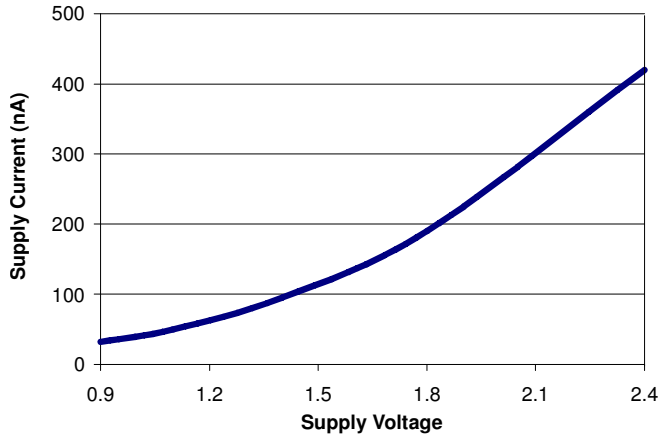

Figure 4. BD0xx-14E supply current vs. voltage.

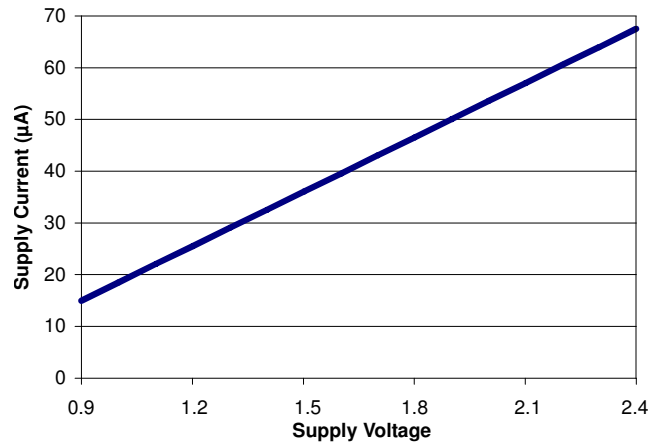

Figure 5. BD927-14E supply current vs. voltage.

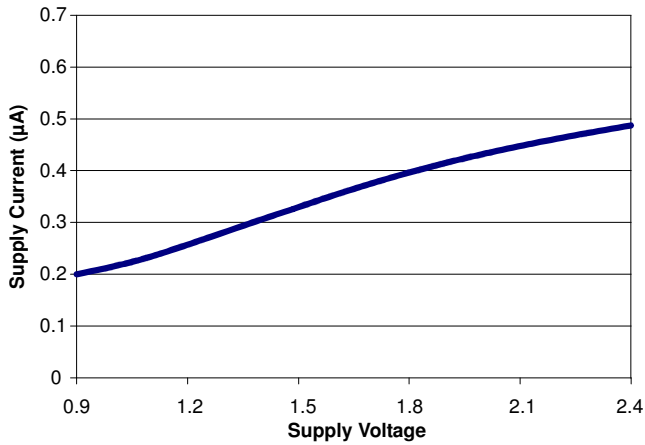

Figure 6. BD940-14E supply current vs. voltage.

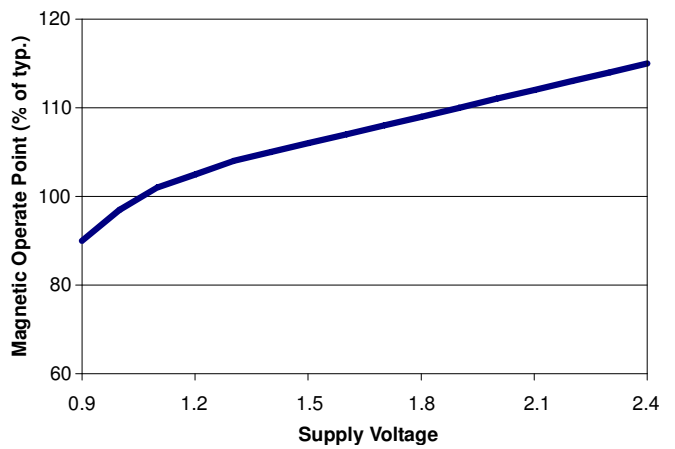

Figure 7. BDxxx-14E magnetic operate point vs. supply voltage.

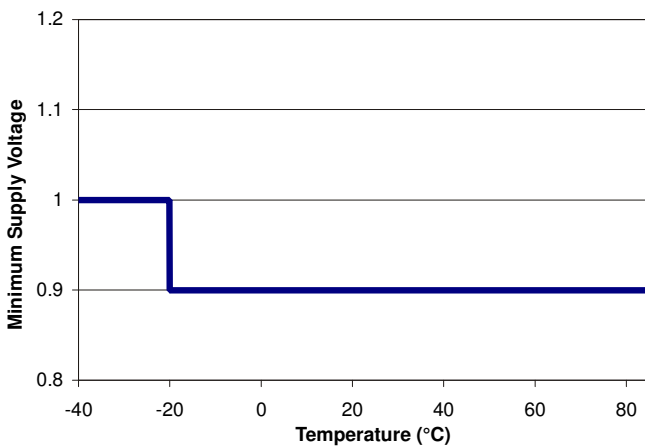

Figure 8. BD0xx-14E supply voltage vs. temperature derating curve.

Typical Performance (cont.)

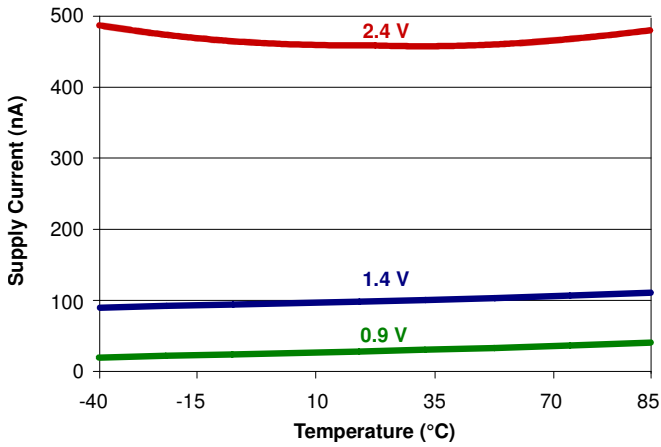

Figure 9. BD0xx-14E supply current vs. temperature and supply voltage.

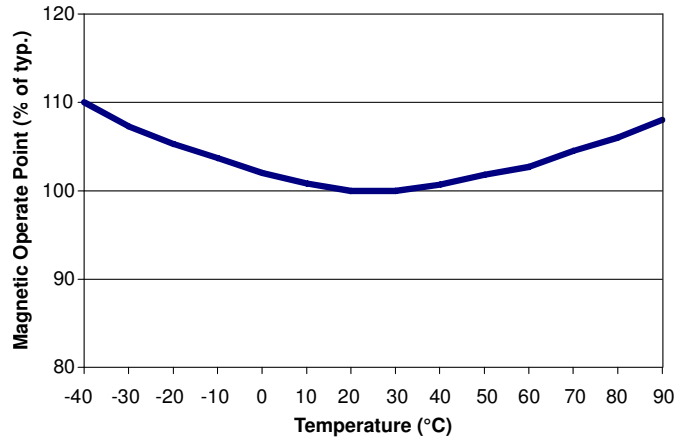

Figure 10. BD0xx-14E magnetic operate point vs. temperature.

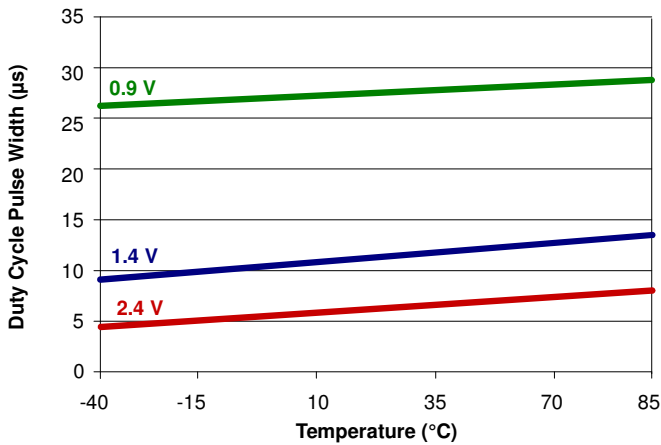

Figure 11. Duty cycle pulse width vs. temperature and supply voltage.

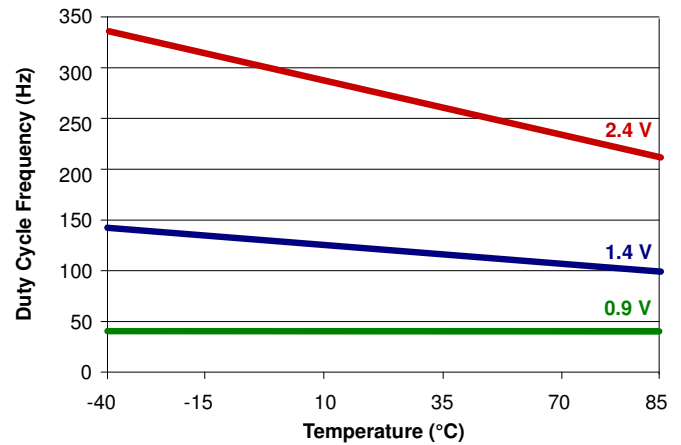

Figure 12. Duty cycling frequency vs. temperature and supply voltage.

Summary of Available Parts

Part Number	Operate Point	Power Consumption	Duty Cycled or Continuous Duty	Package	Features
BD027-14E	1.5 mT	32 nA	Duty-cycled	1.1 x 1.1 x 0.35 mm DFN4	Industry standard.
BD028-14E	1.6 mT	32 nA	Duty-cycled	1.1 x 1.1 x 0.35 mm DFN4	Precise operation point.
BD032-14E	1.6 mT	32 nA	Duty-cycled	1.1 x 1.1 x 0.45 mm DFN4	MRI-Correct output to 3 tesla.
BD036-14E	2.8 mT	32 nA	Duty-cycled	1.1 x 1.1 x 0.35 mm DFN4	Robust high operate point
BD927-14E	1.5 mT	15 μ A	Continuous duty	1.1 x 1.1 x 0.35 mm DFN4	High speed 100 kHz bandwidth.
BD940-14E	1.5 mT	0.2 μ A	Continuous duty	1.1 x 1.1 x 0.35 mm DFN4	Low power TMR; high speed 3 kHz bandwidth.
BHK991-14E	350 mT	1 μ A	Continuous duty	1.1 x 1.1 x 0.4 mm DFN4	TMR for low power; high speed 3 kHz bandwidth; omnidirectional sensitivity; MRI-Correct to 9 tesla.

Application Information

Rigorous Testing

All parts are 100% tested for electrical and magnetic parameters. To ensure quality and reliability in medical applications, BDxxx parts are preconditioned and tested as follows:

- 100% of the parts receive a 24-hour bake at 150°C prior to final test.
- 100% visual inspection of the parts in the tape after final test.
- Lot qualification test where 200 parts that have passed final test from each production lot are exposed to two thermal cycles using a standard solder reflow profile, then re-tested for correct operation. All parts must pass for the parts to be accepted into inventory.

In-Plane or Omnidirectional Sensitivity

As the field varies in intensity, the digital output will turn on and off. The sensors are “omnipolar,” meaning the outputs respond equally to magnetic field of either north or south polarity.

BD0xx, BD1xx, and BD9xx sensors are sensitivity in the plane of the package, unlike Hall-effect sensors. The diagrams below show two permanent magnet orientations that will activate the sensor in the direction of sensitivity:

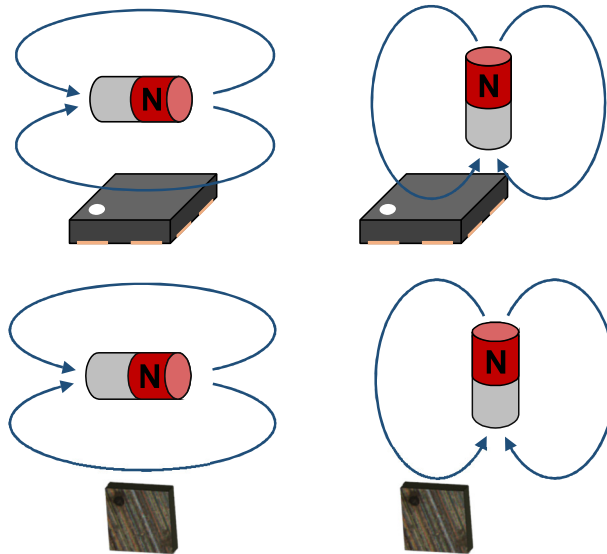

BD0xx/BD1xx/BD9xx in-plane sensitivity.

The BHK991-14E is omnidirectional, meaning it is sensitive to magnetic fields in any direction, so multiple sensors are not needed for orthogonal or unknown directions of applied fields:

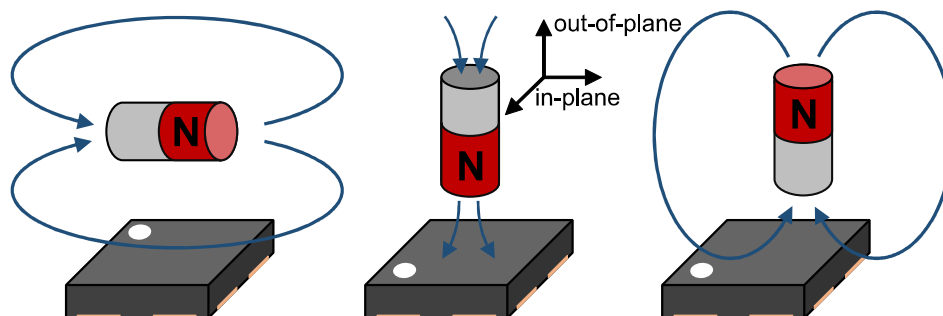

BHK991 omnidirectional sensitivity.

MRI Safety

NVE medical-grade sensors are rigorously tested to ensure they cannot be damaged by magnetic fields of any strength up to 9 tesla. Not all sensors will maintain the correct output state when the magnetic field exceeds a certain threshold, typically beginning around ± 40 mT, however. NVE medical sensors can be characterized as either MRI Safe or MRI Correct. All NVE medical sensors are MRI Safe, but only select medical sensors are designed to also be MRI Correct. If the output state needs to be sampled while inside an MRI machine, the sensor should be MRI Correct.

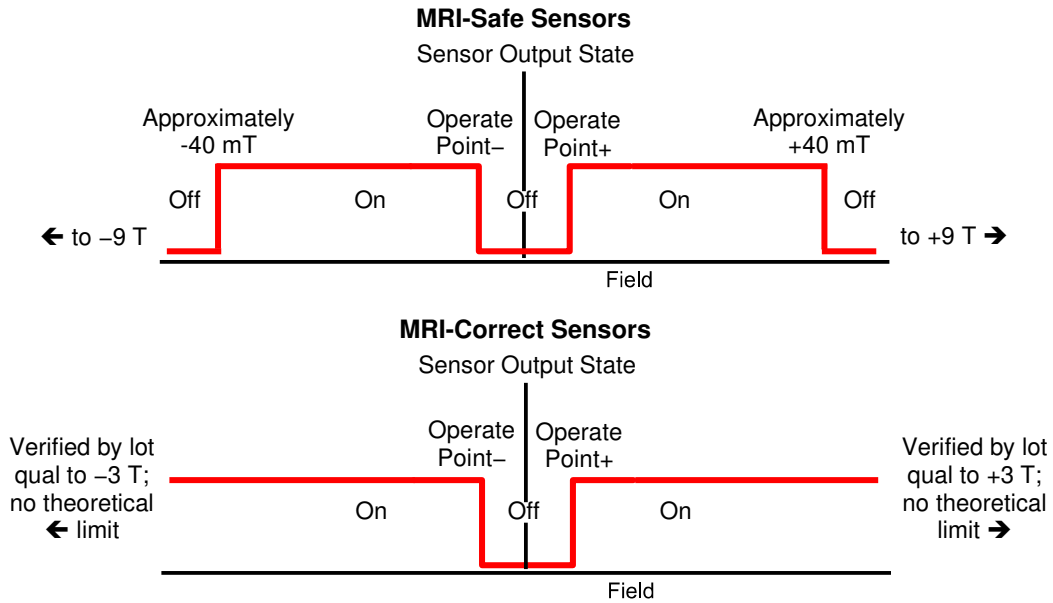

Figure 14. MRI-safe and MRI-correct.

External Duty Cycling of Continuous-Duty Versions

Continuous-duty sensors (BD- and BH-Series) can be externally duty-cycled. Unlike other types of sensors, the switching hysteresis is provided by the magnet sensor element, not a comparator, so the proper hysteresis state is retained when the part is duty-cycled:

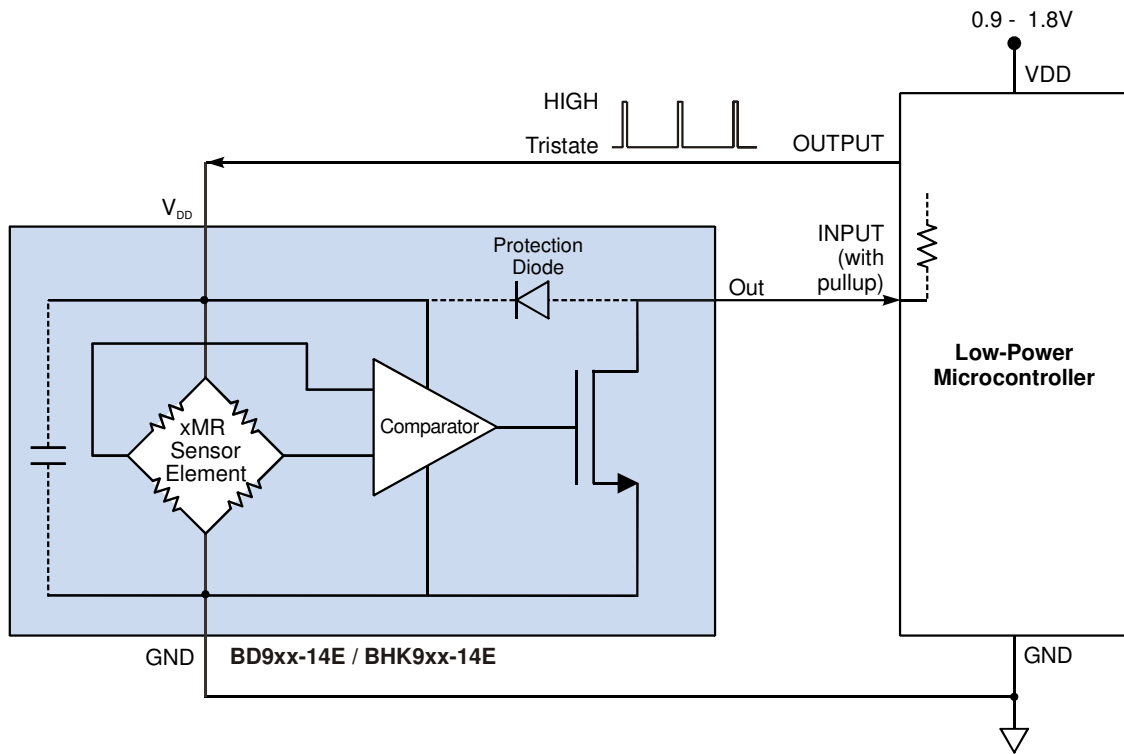
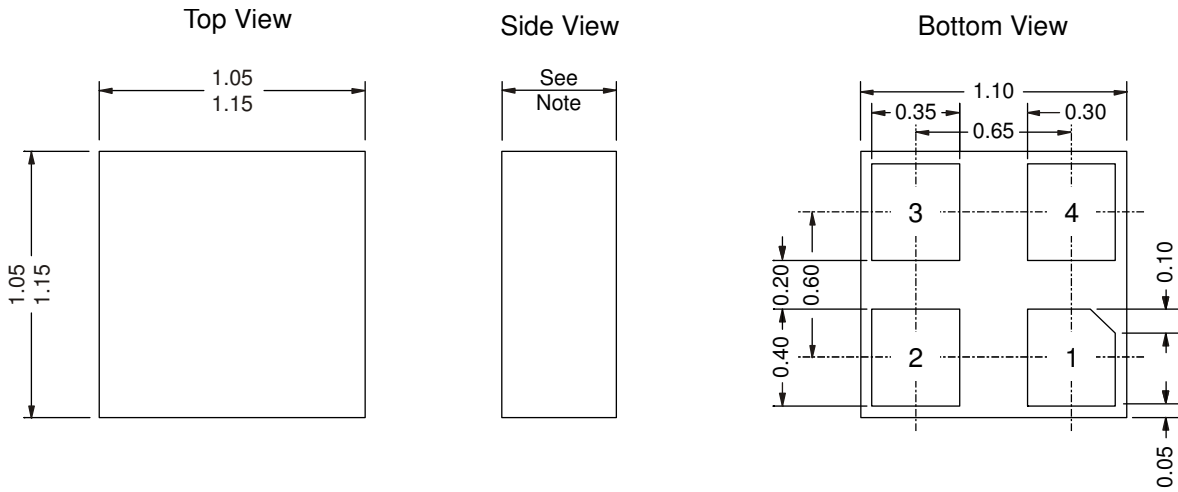

Figure 15. External duty cycling using a microcontroller.

Note that there is a protection diode from the output to V_{DD}, so that if V_{DD} is grounded the sensor output will be low (approximately 0.6 volts), and the pullup resistor will draw current. Therefore, the most efficient way to duty cycle the sensor is to have an output driving V_{DD} to activate the part, and tri-state (rather than grounding) to deactivate the part.

1.1 mm x 1.1 mm DFN4 Package (-14E suffix)



Dimensions in mm; ± 0.05 mm unless otherwise noted.

Part Number	Max. Package Thickness (mm)
BD027-14E	0.35
BD028-14E	0.35
BD032-14E	0.45
BD036-14E	0.35
BD927-14E	0.35
BD940-14E	0.35
BHK991-14E	0.4

Pin 1	No Connect
Pin 2	V_{DD}
Pin 3	Out
Pin 4	Ground



Soldering profile per JEDEC J-STD-020C, MSL 1.

These products have been tested for electrostatic sensitivity to the limits stated in the specifications. However, NVE recommends that all integrated circuits be handled with appropriate care to avoid damage. Damage caused by inappropriate handling or storage could range from performance degradation to complete failure.

Revision History

December 2025

Change

- Initial release of consolidated BD-Series 1.5-volt medical sensors.

Datasheet Limitations

The information and data provided in datasheets shall define the specification of the product as agreed between NVE and its customer, unless NVE and customer have explicitly agreed otherwise in writing. All specifications are based on NVE test protocols. In no event however, shall an agreement be valid in which the NVE product is deemed to offer functions and qualities beyond those described in the datasheet.

Limited Warranty and Liability

Information in this document is believed to be accurate and reliable. However, NVE does not give any representations or warranties, expressed or implied, as to the accuracy or completeness of such information and shall have no liability for the consequences of use of such information.

In no event shall NVE be liable for any indirect, incidental, punitive, special or consequential damages (including, without limitation, lost profits, lost savings, business interruption, costs related to the removal or replacement of any products or rework charges) whether or not such damages are based on tort (including negligence), warranty, breach of contract or any other legal theory.

Right to Make Changes

NVE reserves the right to make changes to information published in this document including, without limitation, specifications and product descriptions at any time and without notice. This document supersedes and replaces all information supplied prior to its publication.

Use in Life-Critical or Safety-Critical Applications

Unless NVE and a customer explicitly agree otherwise in writing, NVE products are not designed, authorized or warranted to be suitable for use in life support, life-critical or safety-critical devices or equipment. NVE accepts no liability for inclusion or use of NVE products in such applications and such inclusion or use is at the customer's own risk. Should the customer use NVE products for such application whether authorized by NVE or not, the customer shall indemnify and hold NVE harmless against all claims and damages.

Applications

Applications described in this datasheet are illustrative only. NVE makes no representation or warranty that such applications will be suitable for the specified use without further testing or modification.

Customers are responsible for the design and operation of their applications and products using NVE products, and NVE accepts no liability for any assistance with applications or customer product design. It is customer's sole responsibility to determine whether the NVE product is suitable and fit for the customer's applications and products planned, as well as for the planned application and use of customer's third party customers. Customers should provide appropriate design and operating safeguards to minimize the risks associated with their applications and products.

NVE does not accept any liability related to any default, damage, costs or problem which is based on any weakness or default in the customer's applications or products, or the application or use by customer's third party customers. The customer is responsible for all necessary testing for the customer's applications and products using NVE products in order to avoid a default of the applications and the products or of the application or use by customer's third party customers. NVE accepts no liability in this respect.

Limiting Values

Stress above one or more limiting values (as defined in the Absolute Maximum Ratings System of IEC 60134) will cause permanent damage to the device. Limiting values are stress ratings only and operation of the device at these or any other conditions above those given in the recommended operating conditions of the datasheet is not warranted. Constant or repeated exposure to limiting values will permanently and irreversibly affect the quality and reliability of the device.

Terms and Conditions of Sale

In case an individual agreement is concluded only the terms and conditions of the respective agreement shall apply. NVE hereby expressly objects to applying the customer's general terms and conditions with regard to the purchase of NVE products by customer.

No Offer to Sell or License

Nothing in this document may be interpreted or construed as an offer to sell products that is open for acceptance or the grant, conveyance or implication of any license under any copyrights, patents or other industrial or intellectual property rights.

Export Control

This document as well as the items described herein may be subject to export control regulations. Export might require a prior authorization from national authorities.

Automotive Qualified Products

Unless the datasheet expressly states that a specific NVE product is automotive qualified, the product is not suitable for automotive use. It is neither qualified nor tested in accordance with automotive testing or application requirements. NVE accepts no liability for inclusion or use of non-automotive qualified products in automotive equipment or applications.

In the event that customer uses the product for design-in and use in automotive applications to automotive specifications and standards, customer (a) shall use the product without NVE's warranty of the product for such automotive applications, use and specifications, and (b) whenever customer uses the product for automotive applications beyond NVE's specifications such use shall be solely at customer's own risk, and (c) customer fully indemnifies NVE for any liability, damages or failed product claims resulting from customer design and use of the product for automotive applications beyond NVE's standard warranty and NVE's product specifications.

An ISO 9001 Certified Company

NVE Corporation
11409 Valley View Road
Eden Prairie, MN 55344-3617 USA
Telephone: (952) 829-9217

www.nve.com
e-mail: sensor-info@nve.com

©NVE Corporation
All rights are reserved. Reproduction in whole or in part is prohibited without the prior written consent of the copyright owner.

SB-00-177

December 2025